

The Caregiver Toolbox

Guide to Independent Living



*Brought to you by the Central Ohio Area Agency on Aging
Your Connection to Care*

800-589-7277

614-645-7250

WWW.COAAA.ORG

2025-2027



COAAA can help
you help the
ones you love.



Help at home for loved ones is just a phone call or email away.

Our staff can advise on hiring in-home help, qualifying for home-care programs, and dealing with the everyday stresses of caregiving.

614-645-7250 | 800-589-7277 | COAAA@COAAA.ORG

Consultations are available via telephone, email, or in your home at no cost to you.

Call Today. We can help you help the ones you love.

Caregiver Bill of Rights

I have the right:

- To take care of myself. **This is not an act of selfishness.** It will give me the capability to take better care of my loved one(s).
- To **seek help** from others even though my loved one(s) may object. I recognize the limits of my own endurance and strength.
- To **maintain facets of my own life** that do not include the person I care for, just as I would if he or she were healthy. I know that I do everything that I reasonably can for this person and I have the right to do some things just for myself.
- To get **angry**, be depressed, and to express other difficult feeling occasionally.
- To **reject** any attempts by my loved one(s) (either conscious or unconscious) to manipulate me through guilt, and/or depression.
- To **receive consideration**, affection, forgiveness, and acceptance for what I do, from my loved one(s), for as long as I offer these qualities in return.
- To take pride in what I am accomplishing and to **applaud the courage** it has sometimes taken to meet the needs of my loved one(s).
- To **protect my individuality** and my right to make a life for myself that will sustain me in the time when my loved one(s) no longer need(s) my full-time help.
- To expect and demand that as new strides are made in finding resources to aid physically and mentally impaired persons in our country, **similar strides will be made towards aiding and supporting caregivers.**

~ Modified with permission from Today's Caregiver Magazine (2006)

The Caregiver Toolbox Table of Contents

Chapter 1: Getting Started and Accessing Aging Services

1.1. Clarifying Your Concerns _____	4
1.2 Accessing Aging Services in Ohio _____	6

Chapter 2: Planning Ahead for Care

2.1 Having the Conversation _____	14
2.2 Important Documents _____	17
2.3 Financial Realities of Paying for Care with Medicare & Medicaid _____	21
2.4 Housing Choices _____	28
2.5 After a Death _____	34
2.6 If You Are a Veteran _____	40
2.7 The Driving Decision _____	44

Chapter 3: Navigating the Healthcare System

3.1 Advocating with Healthcare Providers _____	50
3.2 In the Hospital Setting _____	54
3.3 Palliative Vs. Hospice Care _____	58
3.4 Finding and Managing Care at Home _____	62
3.5 Finding and Managing Care in A Long Term Care Facility _____	74
3.6 Avoiding Abuse, Neglect and Exploitation _____	77

Chapter 4: The Nuts and Bolts of Care

4.1 Adapting the Home for Caregiving _____	82
4.2 Working with Wheelchairs _____	85
4.3 Assisting Someone to Stand, Sit or Transfer _____	88
4.4 Pressure Ulcers and their Care _____	93
4.5 Common Equipment and their Use _____	95
4.6 Safety and Disaster Considerations _____	100
4.7 Managing Medications _____	111

Chapter 5: Preventing Burnout

5.1 Strategies for Identifying, Treating and Preventing Burnout _____	116
5.2 Common Family Dynamics _____	123
5.3 Challenging Care Situations _____	130
5.4 Caregiving Over the Holidays _____	135

Hover and click on any title to go directly to that section.

Chapter 6: Brain Health & Understanding Dementia

6.1	Maximizing Brain Health	142
6.2	What Do We Mean by Dementia?	147
6.3	As The Brain Deteriorates-What Stays and What Goes?	151
6.4	Managing Common Behaviors: Wandering, Bathing, Toileting, Sleeping, Eating	155

Chapter 7: Helpful Websites and Resources 161

Hover and click on any title to go directly to that section.

The Caregiver Resource Manual is brought to you by the Central Ohio Area Agency on Aging. Any unauthorized use and/or duplication of this material without prior express and written permission from The Central Ohio Area Agency on Aging is strictly prohibited. Excerpts and links may be used, provided that full and clear credit is given to Central Ohio Area Agency on Aging with appropriate and specific direction to the original content.

This manual is not a substitute for professional medical or mental advice and care. If you have specific needs, please see a professional health care provider. Any references to products, services, or health care providers are not a recommendation or endorsement of products, services or providers. Links to web sites are provided for convenience and do not constitute or imply endorsement. Every reasonable effort is taken to insure accurate information, however we cannot guarantee completeness or timeliness. COAAA assumes no responsibility for outcomes resulting from the use of information contained in this manual, and COAAA expressly disclaims (denies or renounces) all liability for injury or damages arising out of use, reference to, reliance on, or performance of such information.

CHAPTER 1

Getting Started & Accessing Aging Services

Section 1.1:
Clarifying Your Concerns (p.4)

Section 1.2:
Accessing Aging Services in Ohio (p.6)

CHAPTER 1



Chapter 1

1.1: Clarifying Your Concerns

Look over the areas below and see which of them address the issues that you are currently concerned about regarding your older relative or friend. This exercise can help you know which part of this booklet may be relevant to your needs. Then go back to the table of contents and consult those areas of greatest concern to you.

Social Concerns

Does your loved one have:

- Ongoing contact with other people on a regular basis?
- Any social life outside the immediate family?



NOTES:

Daily Activity/Self-Care Concerns

- Is your loved one able to:
- Do grocery shopping independently?
- Prepare their own nutritious meals?
- Bathe and dress without help and look presentable?
- Keep their home orderly and do housekeeping without assistance?
- Handle emergency situations and know what to do to get help in a medical emergency at home?
- Manage their own finances, pay bills and handle medical forms?
- Manage daily activities without frequent falls/injuries?

NOTES:



Physical Condition Concerns

Does your loved one:

- Have serious health problems?
- Currently receive treatment for health problems?
- Take medications (if so, how many and what kind?)
- Take medications without being reminded?
- Have a disability, making it difficult to get around in his/her own home?

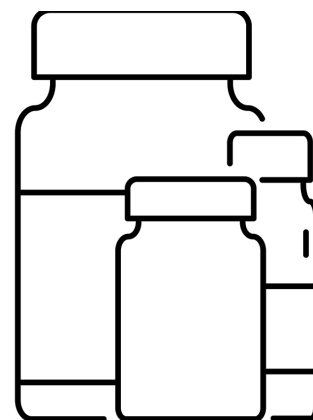

NOTES:

Emotional/Mental Condition Concerns

Does your loved one:

- Become very forgetful or confused about time and dates, where he/she is and what he/she should do?
- Have frequent or unexpected mood changes for no apparent reason?
- Complain about being bored and lonely?
- Cry or seem sad a great deal of the time?
- Lack interest in their favorite hobby or activity?

NOTES:

[Click here to return to the table of contents.](#)

Chapter 1

1.2: Accessing Aging Services in Ohio

Realities of Caregiving in the United States

- People are living longer.
- The fastest growing segment are those age 85+.
- 1 in 4 families are providing care.
- Families are facing many types of caregiving issues.
- Many family caregivers are providing care to older family members with no outside assistance.



Planning Ahead: Having the Conversation

An organized approach to starting a discussion about a person's:

- Current State of Health
- Goals and Values
- Financial Resources Available
- Preferences For Future Care, Treatment and Living Arrangements

Not just a one-time event – should be an ongoing process in families as needs and situations change.

Suggestions for Getting the Conversation Started

- Do your OWN planning.
- Explain why you are bringing the subject up.
- Prepare your questions in advance.
- Prepare background information.
- Consider holding a family meeting to discuss these issues.

What Are Area Agencies on Aging (AAA)?

- Established by the Federal Government in the Older Americans Act of 1965. Every part of the US and our territories are served by a AAA (over 622).
- Most states have multi-county regions served by an AAA. Ohio has 12 regions which are pictured to the right (called Planning & Service Areas- PSA for short). To see a more detailed map of the regions in Ohio, go to www.ohioaging.org

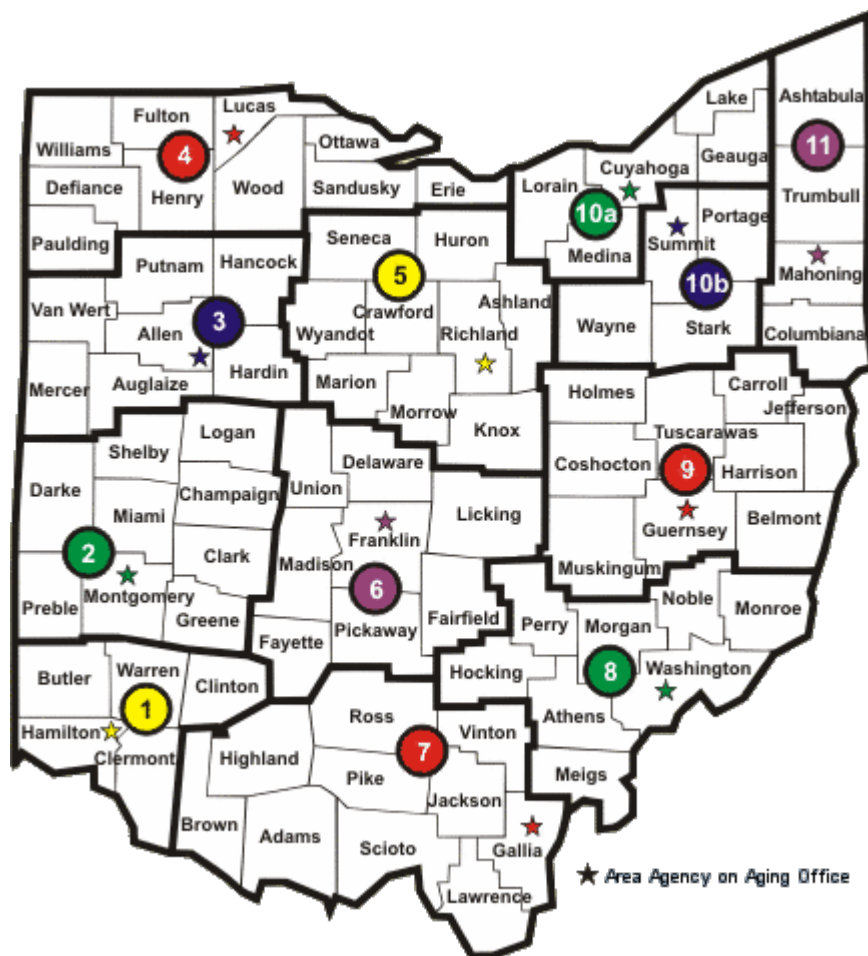

Area Agencies on Aging in Ohio: What Do We Do?

- **Fund** Community Based Services (under Title III of the Older Americans Act)
- **Provide Information, Assistance and Education** to older adults, adults with disabilities and their families on a variety of issues like long term care services, housing, and caregiver support, health and wellness (call or check the website of any AAA to get connected to services and programs).
- **Advocate** on behalf of older adults, adults with disabilities and their families.
- **In Ohio, Administer** programs designed to allow those who are eligible for Medicaid and would be living in a nursing facility to receive care in the community.

Area Agencies on Aging in Ohio by Multi-County Area
Locate Your County in *Italics* Below

Council on Aging of Southwestern Ohio (Area 1)
4601 Malsbary Rd.
Blue Ash, OH 45242
800-252-0155/513-721-1025
(serving Butler, Clermont, Clinton, Hamilton, & Warren counties)

Area Agency on Aging, PSA 2 (Area 2)
40 W. Second Street, Suite 400
Dayton, OH 45402
800-258-7277/937-341-3000
(serving Champaign, Clark, Darke, Greene, Logan, Miami, Montgomery, Preble, & Shelby counties)

Area Agency on Aging 3, Inc. (Area 3)
2423 Allentown Rd.
Lima, OH 45805
800-653-7277/419-222-7723
(serving Allen, Auglaize, Hancock, Hardin, Mercer, Putnam, & Van Wert counties)

Area Office on Aging of Northwestern Ohio, Inc. (Area 4)
2155 Arlington Ave.
Toledo, OH 43609-0624 800-472-7277/419-382-0624
(serving Defiance, Erie, Fulton, Henry, Lucas, Ottawa, Paulding, Sandusky, Williams, & Wood counties)

Ohio District 5 Area Agency on Aging, Inc. (Area 5)
2131 Park Ave. W. Ontario, OH 44906
800-860-5799/419-524-4144
(serving Ashland, Crawford, Huron, Knox, Marion, Morrow, Richland, Seneca, & Wyandot counties)

Central Ohio Area Agency on Aging (Area 6)
3776 S. High St. Columbus, OH 43207
800-589-7277/614-645-7250
(serving Delaware, Fairfield, Fayette, Franklin, Licking, Madison, Pickaway, & Union counties)

Area Agency on Aging, District 7 (Area 7)
1 Acy Avenue
Jackson, OH 45640
800-582-7277/740-245-5306
(serving Adams, Brown, Gallia, Highland, Jackson, Lawrence, Pike, Ross, Scioto, & Vinton counties)

Buckeye Hills Area Agency on Aging (Area 8)
1400 Pike Street
Marietta, OH 45750
800/331-2644 or 740/373-6400
(serving Athens, Hocking, Meigs, Monroe, Morgan, Noble, Perry, & Washington counties)

Area Agency on Aging Region 9, Inc. (Area 9)
710 Wheeling Ave.
Cambridge, OH 43725
800-945-4250/740-439-4478
(serving Belmont, Carroll, Coshocton, Guernsey, Harrison, Holmes, Jefferson, Muskingum, & Tuscarawas counties)

Western Reserve Area Agency on Aging (Area 10A)
1700 E. 13th St. Suite 114
Cleveland, OH 44114
800-626-7277/216-621-8010
(serving Cuyahoga, Geauga, Lake, Lorain, & Medina counties)

Direction Home Area Agency on Aging (Area 10B)
1949 Town Park Blvd.
Uniontown, OH 44685
800-421-7277/330-896-9172
(serving Portage, Stark, Summit, & Wayne counties)

Direction Home of Eastern Ohio (Area 11)
1030 N. Meridian Rd.
2nd Floor Niles, Ohio 44509 800-686-7367/330-505-2300
(serving Ashtabula, Columbiana, Mahoning, & Trumbull counties)

How to Find What Assistance is Available?

- **Eldercare Locator:** 800-766-1116 (www.eldercare.acl.gov) Free information on services anywhere in the United States.
- **Free Long Term Care Assessment:**
- 1-800-589-7277 (www.coaaa.org) Free in home consultation to help families make long term care choices. Can be provided anywhere in Ohio.
- Many counties and local communities have **Senior Citizen Service Handbooks** which list a wide variety of services. Check with your local Area Agency on Aging to see if one is available.

Websites to Check:

- www.aging.ohio.gov- Ohio Dept. of Aging website which highlights many of the programs and services in the state.
- www.ltc.age.ohio.gov- Long-Term Care Consumer Guide Information about nursing homes and assisted living facilities in Ohio. Includes resident satisfaction survey results.
- www.proseniors.org- This website has very comprehensive and easy to understand fact sheets on legal and benefit issues for residents of Ohio. It also offers limited legal advice and referrals to elder law attorneys to older adults and their families through its phone number which is 800-488-6070.
- www.disabilityrightsohio.org- This website has much information about legal issues and services for Ohio residents who have physical and mental disabilities.

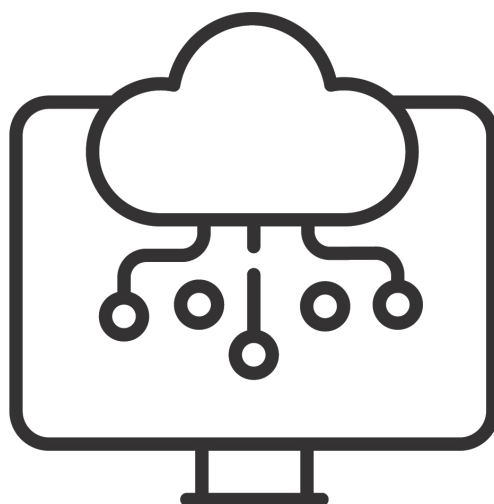

What Types of Services Are Available in Most Communities?

Many cities/towns have numerous services for older adults who wish to receive care while living in their own home, apartment or condominium. The cost/funding for these programs varies by each service. Some services charge a fee, some accept a donation, and some will bill insurance if the person has it and the service is covered.

Adult Day Services – also referred to as Adult Day Care

Programs offering social and recreational activities, supervision, health services, and meals in a protective setting for older adults with physical or cognitive disabilities. Typically open weekdays during business hours.

Chore Services

Assistance with heavy house cleaning, minor home repairs, and yard work.

Companions

Provide conversation, supervision and some help with meals or tasks.

Emergency Response Systems (ERS)

A service that provides individuals with a call button, which alerts a call center to get help from family, friends, or emergency services. Services may include smoke detection and medication reminders. Services/units may be rented or purchased.

Home Health Aides (or Personal Care Aide)

Provide assistance with personal care such as: bathing, dressing, feeding, some minor medical care and light housekeeping.

Homemakers

Provide assistance with light housekeeping, laundry, cooking, and errands.

Home Modification

Changes or additions to the structure of a home to improve safety and accessibility.

Hospice

Services for the terminally ill provided in the home, a hospital, or a long-term care facility. Includes home health services, volunteer support, grief counseling, and pain management.

In Home Therapists

Speech, Physical and Occupational Therapies--Provide training in communication, physical movement or doing daily tasks.

Meal Programs

Meals delivered to homebound individuals or at group dining locations in the community. Typically provided five or more days per week.

Nurses

Provide medical care and medical monitoring.

Respite Care

Short-term care provided for an older person to allow caregivers time away from their caregiving role. Provided by trained professionals or volunteers in the home or by short-term admission to an assisted living or nursing facility.

Senior Centers

Provide social activities, information and a range of services.

Telephone Reassurance

Regular phone calls to check on the person's well-being.

Transportation Services

Provide rides to appointments, shopping, and other activities.

What Is the Role of Local Tax Levy Funded Programs in Ohio?

- In Ohio, local levy funds support for a wide range of home and community based services for older adults. Many counties spend a large portion of their funds on nutrition (community and home-delivered meals), transportation, adult day services and in-home support such as homemaker services.
- Many Ohio counties have countywide property tax levies, based on the fair market value of real estate. A few counties use sales tax and other types of taxes to fund levy services for older adults. For a complete listing in Ohio, go to www.aging.ohio.gov. Most Ohio Levy programs operate on a sliding fee scale so they look at an individual's income and assets to determine cost of assistance.
- In Central Ohio, there are senior service levies in Delaware, Fairfield, Franklin, Licking, Madison, Pickaway and Union Counties. To access their services, visit the www.coaaa.org website for local contact information.



What is a Case or a Care Manager?

- A professional who provides coordination of the services coming into the home. Families involved in long distance caregiving find it especially helpful to hire someone to coordinate home care services.
- Some government funded home care programs include a case manager to assist families in coordinating services.
- Consult the COAAA's Moving and Transition Guide for a list of consultants. Download a guide at www.coaaa.org.
- Locate a private case manager by calling the Aging Life Care Association at 520-881-8008 (www.aginglifecare.org).

What is the Difference Between Medicare and Medicaid?

(for more information go to pages 21-27)

Medicare is an Insurance Program which primarily serves people over 65 regardless of Income. People pay into Medicare through their Social Security payroll taxes. Medicare is a Federal Program—the same across the US.

Medicare covers hospital care, doctors and other health care provider's bills—most of its care is short term in nature and provided by a health care professional. For more information go to www.medicare.gov.

VS.

Medicaid is an Assistance Program which serves low-income people of any age. Medicaid is paid for by both the Federal and State governments, so the services can vary from state to state. In Ohio, Medicaid eligibility is based on limited income, assets and medical expenses. You apply for benefits at the Dept. of Job and Family Services or online at www.benefits.ohio.gov. The phone number is 800-324-8680.

Medicaid can cover hospital care, doctors and other health care provider's bills, but it also covers long term care needs. These can be provided in an institution or in the community through a Medicaid Waiver program.

What Is a Medicaid Waiver Program?

Ohio has several programs which are designed to provide home and community based care to those who would otherwise be living in a long term care facility on Medicaid. Some of these are:

- **PASSPORT**

- Age 60 or older & financially eligible for Medicaid institutional care
- Has enough daily needs to require a nursing home level of care
- Able to remain safely at home with the consent of their physician.
- The cost of PASSPORT services needed at the time of application cannot exceed 60 percent of the cost of nursing home care.

- **Assisted Living Waiver**

- Available for those in Ohio over the age of 21 living in a participating assisted living facility.
- Pays the costs of care in an assisted living facility, allowing the person to use his or her resources to cover "room and board" expenses.
- Next Gen My Care Ohio Waiver
- Parts of the state including Central Ohio have been part of a demonstration program called "MyCare Ohio" in which Managed Care Organizations assume responsibility for people who are eligible for BOTH Medicare and Medicaid. Starting in 2026, the entire state will participate in a program which is replacing this for all people who are eligible for both Medicare and Medicaid called "Next Gen My Care Ohio. For more information, see www.medicaid.ohio.gov.

Click here to return to the table of contents.

CHAPTER 2

Planning Ahead for Care

Section 2.1:
Having the Conversation (p.14)

Section 2.2:
Important Documents (p.17)

Section 2.3:
Financial Realities of Paying for Care with
Medicare & Medicaid (p.21)

Section 2.4:
Housing Choices (p.28)

Section 2.5:
Before and After a Death (p.34)

Section 2.6:
If You are a Veteran (p.40)

Section 2.7:
The Driving Decision (p.44)

CHAPTER 2



Chapter 2

2.1 *Planning Ahead for Care—Having the Conversation*

As people age, they may have new healthcare challenges, different housing needs, or look to others to assist with some aspects of their day to day life.

Older individuals and their families may be unfamiliar with all of the resources which are available to assist them. In addition, families often do not discuss these issues ahead of time. It is important to clarify your areas of concern and to become familiar with the services and providers in your area. This can help families have an easier time making difficult decisions when the time comes.



Planning Ahead-What Is It?

- An organized approach to starting a discussion about a person's:
- Current State of Health
- Goals and Values
- Available Financial Resources
- Preferences For Future Care, Treatment and Living Arrangements
- Not just a one-time event-should be an ongoing process in families as needs and situations change.

WHY Do People Delay?

- Uncomfortable topics
- Easy discussions to delay.
- Confusing topics—in terms of legal documents and what they mean.
- Denial and lack of recognition of what is happening or COULD happen.
- Don't want to burden others.
- People in families often disagree and this can lead to conflict.

WHAT Topics to Discuss?

- Changes in living environment/housing.
- Needs for more care.
- Health diagnosis/prognosis.
- Treatment options: medicine, surgery.
- End of life interventions: hydration, nutrition, other life sustaining treatments.
- Pain management.
- Money—financial realities.
- Funeral or after death plans.

WHEN Could Conversations Happen?

- The Next Holiday
- AFTER an illness or a medical treatment.
- BEFORE the next illness or medical treatment
- The next planned face to face visit.
- The next family gathering.
- When people are NOT too tired!!

SUGGESTIONS for Getting the Conversation Started

- Do your own planning.
- Explain why you are bringing the subject up.
- Prepare your questions in advance.
- Prepare information.
- Consider holding a family meeting

CONSIDER Holding a Family Meeting

- Don't forget to include as many people as possible including long-distance family/ caregivers.
- Include 3rd and 4th generation family members if available (adults). They often bring a productive dynamic to the discussion and a current knowledge of technology.
- Set ground rules for the meeting so that only issues that apply to the current concerns are brought into the discussion (i.e. leaving out old arguments, past issues etc.)
- Appoint a mediator who will move the discussion along. This can be someone from the family, a close friend or it can also be appropriate to hire someone who specializes in these issues. Everyone should have a chance to share and listen to the others.



The Conversations Project

- Started in 2012 by Journalist Ellen Goodman—her TED Talk in 2014 is on YouTube
- Offers different discussion guiding documents to download
- Started the Conversation Sabbath Movement which is an initiative in churches in October-November

Downloadable Documents from The Conversations Project

- *Your Conversation Starter Kit*
- *Your Conversation Starter Kit for Dementia*
- *Your Conversation Starter Kit for Pediatrics*
- *How to Choose/Be a Health Care Proxy*
- *How to Talk to Your Doctor/Health Care Provider*
- *What Matters to Me Workbook*

Download these from <https://theconversationproject.org/>

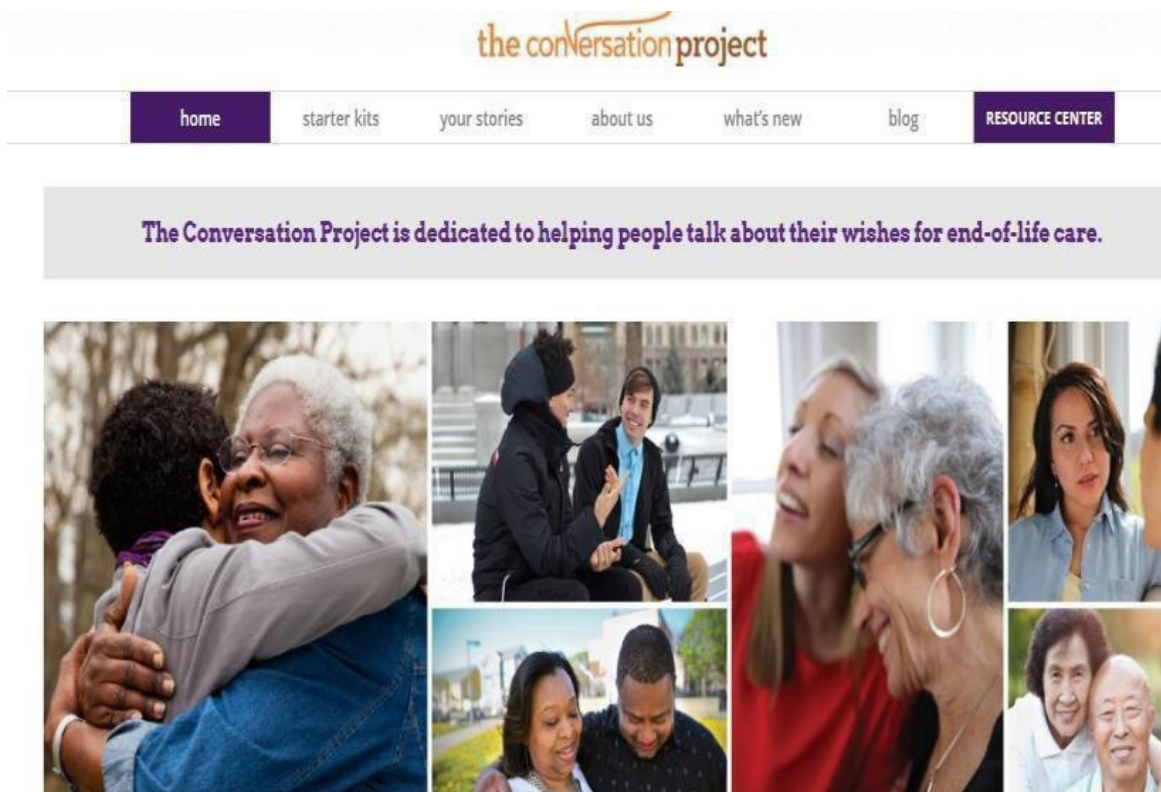

Click here to return to the table of contents.

Chapter 2

2.2 Planning Ahead for Care — Important Documents

WHAT are Important Documents?

ANY Document That Provides Information About Your:

- Legal Wishes During Life and After Death
- Legal Contracts and Binding Documents
- Assets and Investments
- Financial Status & Benefits
- Health Insurance & Benefits
- Planning Professionals' and Medical Providers'
- Contact Information
- Passwords to Online Accounts and Other Information About Them
- Family and Friends' Contact Information



WHERE Should You Keep Important Documents?

- All together as much as possible.
- Secure location in house like a fireproof safe.
- Copies in a second location.
- Safe Deposit boxes in banks-These are safe but may NOT be accessible to anyone whose name is not on the contract. Do not store documents that family might need to access immediately here unless the family member's name is on the account.
- In a location where family members (you wish) can access should you be unavailable for whatever reason.

TELL your family of these locations!

ACCESSING Planning Professionals (Legal & Financial)

- They provide advice and guidance.
- They provide proper execution of wishes.
- Make sure the person is licensed and credentialed in the state in which the individual hiring the services lives.
- Ask about the person's specializations (many of them serve certain populations or specialize in one area of their field).
- Ask and expect clear, written information about fees.
- How to find professionals:
- Check professional association websites.
- Ask other professionals you trust.
- Ask friends for references.

Helpful Websites

Find up to date legal information on these websites and links to BLANK documents for Ohio:

- www.ohiolegalhelp.org
- www.proseniors.org
- www.ohiobar.org
- www.ohiodisabilityrights.org

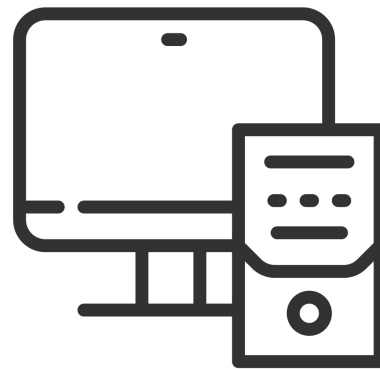

Powers of Attorney In Ohio

- Health Care and Financial Powers of Attorney are two DIFFERENT legal instruments in Ohio. Some states call this naming a “Proxy” or an “Agent” (which means a person to carry out your wishes when you cannot).
- Typically, they are used when you are UNABLE to make your own decisions any longer. You can grant them to 2 different persons or both to the same person.
- You can name a PRIMARY PERSON and several alternates if that person is unavailable.
- YOU GRANT them when you are healthy and mentally competent. YOU can revoke them at any time when you are healthy and mentally competent.
- They cannot be changed or revoked by anyone else but you.
- You do not need a lawyer to complete these documents. However, they do need to be witnessed and/or notarized in Ohio.
- They generally end at your death though the health care power of attorney can arrange for a body to be removed to a mortuary.



Living Will in Ohio

- A legal document that specifies your wishes to doctors regarding the use of life-sustaining treatments if you should become terminally ill or permanently unconscious.
- It becomes effective **ONLY** when you are unable to communicate your wishes.
- You do not need a lawyer to complete this document.
- You can change or revoke it at any time but it cannot be changed or revoked by anyone but you.

Organ and Tissue Donation in Ohio

- The Ohio Donor Registry was established in July 2002.
- It provides Ohioans the opportunity to give legal consent to be an organ, eye or tissue donor at the time of death.
- An individual may sign up anytime online at <https://donatelife.ohio.gov/> or by saying “yes” when receiving or renewing their driver license or state ID at the Bureau of Motor Vehicles.

Do Not Resuscitate Order in Ohio (DNR)

- An order issued by a medical provider which says that a person does not want different forms of Cardiopulmonary Resuscitation (CPR).
- Ohio’s DNR order relieves emergency medical services (EMS) personnel and other medical professionals and facilities of their DUTY to resuscitate a person if they are presented with this document.
- There are TWO kinds of Orders in Ohio: Comfort Care Arrest or Comfort Care.
- The difference between them is WHEN they are invoked.
 - Comfort Care-Arrest is **ONLY** invoked when a person is suffering from cardiac and/or respiratory arrest.
 - Comfort Care is invoked **IMMEDIATELY** upon the onset of any emergency incident requiring life saving intervention.
- These orders can be revoked by the person through his/her healthcare provider at any time.
- For more information and to download a blank form, go to the Ohio Dept. of Health website (www.odh.ohio.gov) and search for Do Not Resuscitate Orders.

Guardianships in Ohio

- Under Ohio law, if you are mentally impaired to the point that you cannot take proper care of yourself, your property or those for whom you are legally responsible, you may be determined incompetent and have a guardian appointed.
- A guardian may be appointed over the person or the estate or both.
- A GUARDIAN OF THE PERSON is responsible for the physical care of the person.
- A GUARDIAN OF THE ESTATE is responsible for the person's finances.
- THE COUNTY PROBATE COURT appoints and manages all guardianships in Ohio. To obtain information or application forms, contact your county probate court.



Wills in Ohio

- A will is a formal document that lets you provide for the distribution of your estate when you die.
- An estate consists of any property you own at death:
 - Real Estate Property (House and Land)
 - Personal Property (Stocks, Bank Accounts, Cars)
 - Intangible Property (Claims, Interests, Rights)
- Ohio law permits anyone 18 or older, of sound mind to execute a will. Your will must be in writing. You must date and sign the will in front of two competent witnesses.
- In your will, you will name an "Executor," which is a person who has responsibility for representing you after your death and distributing your goods between those listed in your will.
- In the case of multiple wills, the most recent one is legally binding.

Other After Death Declarations

- Ohio allows many other documents to have "Transfer on Death" (TOD) options.
- These include vehicles, bank accounts, & property.
- Many people execute these documents while they are still healthy and competent.

[Click here to return to the table of contents.](#)

Chapter 2

2.3 Planning Ahead for Care—Financial Realities of Paying for Care with Medicare & Medicaid

Medicare

- Federal health insurance program
- Eligibility:
 - People age 65 and older.
 - People with End Stage Renal Disease or Amyotrophic Lateral Sclerosis (ALS).
 - People who have been receiving Social Security Disability payments for 24 months.
 - Everyone who pays into Social Security System earns coverage (FICA taxes).



Medicare Part A

- Also called hospital insurance.
- Automatic and free for those paying into Social Security for at least 10 years.
- Coverage for: hospital care, post-hospital skilled rehabilitative care, and hospice care. These different types of care are described on the next few pages of this guide.

Medicare Part B

- Also called Medical Insurance.
- Coverage is voluntary.
- Current premiums for most people range from \$185.00-259.00 (2025). Premiums are based on income.
- Coverage for: Doctors, Lab/Diagnostic Services, Some Durable Medical Equipment, Limited Ambulance, and Home Health Care.
- Pays 80% of cost after a yearly deductible of \$257.00 (2025).
- Ohio has a "Balanced Billing Ban" in which providers cannot bill Medicare recipients more than the 20% Medicare allows.

Medicare Part C – Medicare Advantage Plans

- Medicare recipients can choose a Medicare Advantage Plan as their Medicare coverage.
- These operate like HMOs or PPOs.
- Advantage Plan members agree to go to providers who are in the plan’s network.
- Plans typically offer prescription drug coverage.
- Plan service areas are typically limited to a city or county.
- Plans may charge an additional monthly premium in addition to the Part B premium – the premium varies by plan.
- Some plans pay for over the counter health products, health club memberships, medical transportation, eye glasses and hearing aids.

Medicare Part D – Prescription Drug Coverage

- Available to all Medicare recipients if they do not have coverage from another source that is at least as comprehensive.
- Part D premiums vary by plan.
- Limited Income Subsidy (LIS) provides financial help with purchasing a plan for people who meet financial eligibility. Also called “Extra Help.”
- The website www.medicare.gov provides cost comparisons on plans or contact COAAA 800-589-7277 to speak to a Medicare Specialist.

Medicare Skilled Home Health Care BENEFIT

- Does not pay for non-medical services or private-duty nursing.
- Requires a doctor’s order for all covered services.
- Requires the individual to be homebound.
- Pays for home care typically on a very time-limited basis.

Medicare Skilled Home Health Care SERVICES

- Skilled nursing service or therapy (physical/occupational/speech).
- A home health aide and/or medical monitoring.
- Some medical equipment like hospital beds or wheelchairs.
- Patient/Caregiver education to use medical equipment, perform dressing changes, maintain functioning, manage medications.

Medicare Skilled Nursing Facility Rehabilitative Services Benefit

- Requires 3 consecutive midnights ADMITTED for hospital care prior to nursing facility admission.
- Verify with hospital staff what the person's status is in the hospital.
- If the person's status in the hospital is "OBSERVATION" Medicare does not cover a rehabilitation stay in a nursing facility.
- Medicare only pays for nursing facility care as long as the person needs skilled nursing care or therapy, AND makes progress toward recovery as a result.

Medicare Hospice Benefit

- Requires a terminal diagnosis of 6 months or less (the benefit can be renewed if death does not occur in 6 months).
- Covers all care related to the terminal diagnosis. But care for the overall person's day to day needs is limited.
- Focus is on pain and symptom management or "comfort care."
- Does not cover curative treatment of diseases and conditions.
- Hospice care can be provided in the home, or in a care facility (see p. 58-61 of this booklet for more details)

Medicare Supplemental Insurance

- Regulated and standardized in Ohio.
- 8 different policy types—all fill in the gaps for Medicare (e.g.. co-pays, deductibles.)
- Cannot drop you or raise your premium because you are sick but the monthly premiums do go up as you get older.

Long-Term Care Insurance

- Not regulated or standardized in Ohio.
- Buyer beware! Good and bad policies are out there...be careful not to be pressured into buying.
- Can cover care in both nursing facilities and at home.
- Tend to be much more expensive as a person gets old and/or develops illnesses.

Ohio Dept. of Insurance (OSHIIP program) has booklets and programs that teach about these policies www.insurance.ohio.gov

Medicare Savings Programs

- Programs that assist with Medicare out-of-pocket expenses – income/asset eligibility criteria apply.
- Qualified Medicare Beneficiary (QMB):
 - Pays Medicare Part B premiums, deductibles, and copayments
- Specified Low Income Medicare Beneficiary (SLMB)
 - Pays Part B premiums
- Qualified Individual (QI)
 - Pays Medicare Part B premiums
- QMB/ SLMB/QI - ALL qualify the person for “Extra Help” with Medicare Part D
 - Prescription Drug Coverage.
- Apply at the County Department of Job & Family Services.
- For more information go to: www.insurance.ohio.gov for the flyer “Ohio Medicare Savings Programs.”



Medicaid in Ohio

- Medicaid is a joint State/Federal assistance program for people who cannot afford healthcare.
- There are limits on the amount of income & assets a person can have to be eligible for Medicaid.
- Medicaid ALSO pays for long-term care in the home, assisted living, or a nursing home when a person’s resources are depleted.
- In Ohio, application for Medicaid is through the County Department of Job & Family Services in the county where the person resides.

For more information, go to www.medicaid.ohio.gov or call 800-324-8680.

Community Medicaid

- Also Known as “Basic Medicaid”
- Available to individuals living in the community who are aged, blind, or disabled and have limited income and assets.
- Children, Pregnant Women, & Families in Ohio with limited incomes may also qualify for Community Medicaid with no look at assets.
- Ohio participates in the Medicaid Expansion Project which provides Basic Medicaid Health Coverage to adults ages 18-64 who are at or below 138% Federal Poverty Level.



Institutional Medicaid

- Covers care in a nursing facility once an individual has spent down their assets. Also known as “Long Term Care Services and Supports” (LTSS)
- Eligibility:
 - US Citizen, lawful permanent resident whose date of entry is prior to August 22, 1996, or a qualified alien and a resident of Ohio.
 - Blind, disabled, or 65 or older, and in need of nursing facility services.
 - Monthly gross income at or below \$2644.00 (2025).
 - Countable resources not to exceed \$2000.00.
- Eligibility may go back three months from the application date.

Institutional Medicaid

Income Rules

- Only the income of the applicant is counted.
- The spouse and/or dependents living in the community may be allowed a portion of the institutionalized person’s income.
- Individuals with income over \$2644.00 can still qualify for Institutional Medicaid (excess income over this amount must be deposited in a Qualified Income Trust (QIT). See fact sheet on QITs at www.proseniors.org.

Institutional Medicaid – Asset Rules

- For the institutionalized person, “countable” assets can be no greater than \$2000.00.
- Half of the assets up to approximately \$157,920.00 (2025) can be protected for the spouse living in the community. (Amount changes yearly).
- Countable assets include cash, savings, checking accounts, certificates of deposit, IRAs, real estate property, mortgages, land contracts.
- THE HOUSE OF RESIDENCE IS NOT COUNTED as an asset for Medicaid eligibility as long as the person, his/her spouse or a dependent live in it!!
- For a single individual NOT planning to return home from a nursing facility, the house becomes a countable asset and must be sold to pay for care until the assets are again at \$2000.00.
- Personal belongings, life insurance with a face value of no more than (\$1500) are NOT counted as assets for Medicaid.
- Pre-paid funeral plans as well cemetery arrangements are not a countable asset.
- Assets transferred for less than fair market value within 60 months of application for Medicaid may result in a penalty. The penalty is denial of Medicaid benefits for the period of time the assets would have paid for nursing facility care.

Medicaid Waivers in Ohio for Home Based Care

- Medicaid waivers are programs that fund in-home services to allow an individual to live at home instead of living in a nursing facility.
- Waivers use the same income/asset rules as Institutional Medicaid.
- An individual must also be determined to be at a level of care typically provided in a nursing facility. Level of care is assessed by the Area Agencies on Aging.
- Services include: Personal Care, Homemaker/Chore, Adult Day Services, Home-Delivered Meals, Medical Transportation, Emergency Response Systems, Medical Equipment and Supplies.
- There are several different waivers depending on the person’s age and disability type. Only the PASSPORT waiver for those over age 60 is described here. Go to www.odm.ohio.gov to read about the others.

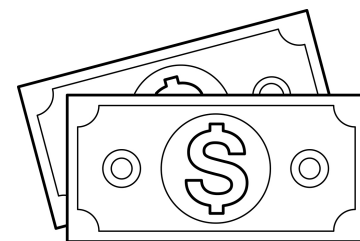

The PASSPORT Medicaid Waiver

- PASSPORT Waiver is for people aged 60 and older.
- Apply through the Area Agency on Aging for PASSPORT.
- Application includes a phone screening, assessment, and application for Institutional Medicaid through the County Department of Job & Family Services.
- Assessments are free, and an individual can re-apply if initially determined not eligible.
- Individuals who have BOTH Medicare and Medicaid transition to the **MyCare Waiver** in certain Ohio counties that participate in a pilot project. This project will go statewide in 2026 and be called "Next Gen My Care."
- Next Gen MyCare provides for a Managed Care Organization to coordinate the health care and long-term care benefits for people who have Medicare & Medicaid.

Helpful Websites

- www.aging.ohio.gov Long Term Care Consumer & Quality Navigator Guides provide information about nursing homes and assisted living facilities in Ohio. Includes resident satisfaction survey results.
- www.medicare.gov -This is the Federal Government's Medicare website. It has a number of areas called "Compare Areas" that allow you to search for various providers who accept Medicare.
- www.proseniors.org – This web site has very comprehensive and easy to understand fact sheets on legal and benefit issues for residents of Ohio. It also offers limited legal advice and referrals to elder law attorneys to older adults and their families through its phone number which is 1-800-488-6070.

Medicaid Estate Recovery

- Federal law allows Ohio Medicaid to make a legal claim against the estate when the Medicaid recipient and spouse have both died, and there are no surviving children under the age of 21, and no surviving disabled children.
- Estate Recovery may be deferred or waived by the state if it is established that it will create undue hardship (a family-owned business or a farm) that is the survivor's sole source of income.
- Consult an attorney experienced in Ohio Medicaid law early on in the Medicaid planning process for guidance regarding estate recovery.

Click here to return to the table of contents.

Chapter 2

2.4 Planning Ahead for Care—Housing Choices

Where We LIVE

- One of our most important decisions in life
- Impacts our physical, emotional, & spiritual well-being
- Many considerations:
 - Financial
 - Health
 - Service Needs
 - Social



The Concept of “Aging in Place”

- Based on the belief that most people desire to live in their own homes as long as possible.
- “Home” may be a residence they own or rent as an individual, or a “group” living arrangement.
- Implies that the person will be supported where they choose to live as their functional needs change over time.

What It Takes To “Age In Place

- PLANNING!!!!
 - Assessment Of Personal, Preferences & Lifestyle Financial Options
 - Legal Issues
 - Long-term Care Options Home Design

Livable Communities

- Support older adults who wish to age in place.
- Involves re-thinking community design, planning, and services in light of: housing, transportation, workforce development, civic engagement, human services.
- Partners for Livable Communities at <https://livable.nonprofitsoapbox.com>



WHAT the Words Mean

Living Arrangements for Older Adults



- Independent Living
 - May be in personal residence or a campus/facility setting.
- Assisted Living
 - Various types of housing that includes services.
 - Marketing Term in Ohio—**not** a licensing term-has lots of different meanings. Licensed by the Ohio Department of Health as Residential Care Facility in Ohio.
- **Memory Care** is **not** a different type of license in Ohio; it is a term that the facilities use to market a type of care in their facility.
- Nursing Home Care or Care Facility
 - Twenty-four (24) hour facility-based nursing care. Licensed by the Ohio Department of Health.

Determining Care Needs

- Activities of Daily Living (ADLs)
 - Personal activities an individual needs to perform to live independently including, eating, bathing, dressing, toileting, and getting in and out of bed, or chairs.
- Instrumental Activities of Daily Living (IADLs)
 - Activities important to living independently, such as using the telephone, doing housework, preparing meals, managing money, shopping for groceries or personal items.

Level of Care

- **Skilled Level of Care:** The person has medical and rehabilitation needs.
 - Medicare and Medicaid both cover.
- **Intermediate Level of Care:** The person has medical ongoing needs to maintain functioning.
 - Medicaid covers, Medicare does NOT cover.
- **Protective Level of Care:** The person has-non medical needs to maintain functioning.
 - Medicare and Medicaid DO NOT COVER.

Independent Living

- Key is self-sufficiency.
- The person is able to maintain the residence and themselves without regular day to day assistance.
- Independent living settings usually do NOT meet the needs of people who have significant confusion.

Independent Living: Home/Condo Ownership--4 Questions

1. Is remaining at home a short or long-term plan?
2. How will the person's social, health, care, and financial needs be met?
3. How will home maintenance be managed?
4. Does the design of the home/condo allow for safety, accessibility, and comfort (for example: location of major rooms, presence of stairs, accessibility of bathrooms, kitchen and laundry)?

Home Owner Resources

- Property Tax Relief – Homestead Exemption In Ohio, Via County Auditor's Office
- Home Repair & Weatherization Programs
- Utility Assistance Programs (HEAP)
- Reverse Mortgages
- Home modification products & features
- "Universal Design" remodelers
- Long-term care insurance (that has home care benefits)

These are all described in detail in the COAAA's Central Ohio Senior Housing and Home Repair Guide which can be downloaded on www.coaaa.org or call and request a hard copy be mailed at 614-645-7250.



Home & Community-Based Services

- Available to individuals living in their own homes or apartments.
- Available through government-funded programs and private fee for service companies.
- COSTS can vary widely depending on the person's needs and the program/company – HOWEVER, these services are generally less expensive for families than placement in a care facility or other group setting.

TYPES of Services Which May Be Available

- Meal Programs
- Transportation Services
- Respite Care
- Adult Day Health
- Home Health Aide (or Personal Care Aide)
- Companions
- Homemakers
- Chore Services
- Medic Alert Programs
- Minor Home Modifications
- Telephone Reassurance
- Nurses
- In Home Therapists
- Case Management/Care Coordination

Independent Living Senior Apartment Complexes

- Lower cost, rent sometimes based on income.
- Can be subsidized under HUD and private non-profits.
- Age criteria may be 55+ or 62+.
- Typically have long waiting lists, can be months or years.
- Buildings have some adaptations, handrails, emergency pull-cords, accessible design.
- May have organized transportation & service facilitators.
- Residents CAN receive outside home and community-based services.

Independent Living: Retirement Communities

- Groups of homes, condos or apartments restricted to people 55+ or 62+.
- May lease or buy unit, may be a campus or subdivision with common areas.
- Residents typically have the option to pay for some services such as housekeeping and meals.
- Amenities can include beauty shops, gardens, pools, activity rooms.
- May have an additional monthly fee for services/amenities.

Continuing Care Retirement Communities (CCRCs)

- Another way to “age in place” & provide continuity.
- Typically campus settings designed to meet housing and service needs as these change over time.
- Often Includes independent living, assisted living, and nursing facility care.
- Couples can receive care based on each individual’s needs.
- Typically a long-term contract and have buy-in or entrance fees, plus monthly fees.
- Often a binding life-long contract with a commitment from CCRC for care— can be a very expensive option.
- Variation based on living space, amenities, service contract, risk of needing intensive long-term care.
- Contracts are binding; it is important to get financial and legal advice before making this decision.

Assisted Living Facilities

- Various types of housing that include services.
- A middle ground between independent living and nursing home.
- Residents may be of any age over 21.
- Appropriate for people who can no longer live on their own but do not require ongoing medical care.
- Regulations Vary Widely From State To State.
- Provide more privacy, autonomy, space, and home-like environment than a nursing home—usually provides meals and some non medical services.
- Appropriate when supervision is needed throughout the day and/or to meet intermittent care needs throughout the day.
- Some Assisted Living Facilities have specialized care units for dementia called Memory Care. These provide more care yet it still must be non medical.
- Rates -Can be all inclusive or base rate with additional per-service fees (Range from \$3500-7500 per month).
- Sources Of Payment:
 - MOSTLY Private Pay in Ohio
 - Long-term Care Insurance Benefits
 - Ohio Assisted Living Medicaid Waiver (Not all communities participate and ones that do, may have private pay times i.e. 1 year private pay etc.)
 - Veterans Benefits (Very Limited and generally for the veteran who has a service connected disability, see p. 40-43 in this guide for more on VA Services.)

Nursing Facilities

- Key difference from assisted living is the need for physician-supervised medical care which is ongoing.
- Typically provides long-term residential care.
- Can also provide short-term rehabilitation stays.
- Can provide short-term respite stays for caregiver relief.
- Highly regulated in all states.



Offers:

- Furnished room (private or shared)
- Dietary services
- Housekeeping services
- Personal care
- Therapeutic recreation
- 24 hour on-site nursing staff
- Physician-supervised care
- Evaluation, care planning
- Medical transportation

MAY Provide:

- Pharmacy
- Dental
- Radiology
- Podiatry
- Hospice
- Mental Health
- Dementia care
- Dialysis

COST

- Between \$6000-10,000 per month. Sources of Payment:
 - Private Pay
 - Long-term Care Insurance
 - Medicaid (after spending down assets—state regulations differ (see p.24-27 of this guide for information in Ohio.)
 - Medicare (Short-term Rehabilitative Stays Only-Requires a 3 night admitted hospital stay, NO Coverage for extended period of time)
 - Veterans Benefits (Generally for the veteran themselves who has a service connected disability and may only contract with certain facilities)
- WHEN to Consider Nursing Facility Care
 - When an individual can no longer care for their own personal needs, (ADLs) due to physical, emotional, or mental problems.
 - When the primary caregivers (family/friends) can no longer manage lifting, incontinence, or supervision of the individual needing care and, available services and supports (formal and informal) are not adequate to meet the person's care needs.

[Click here to return to the table of contents.](#)

Chapter 2

2.5 Planning Ahead For Care—Before and After a Death

When Death Occurs

- Unexpected death (at home or elsewhere): Call 911. The body may be temporarily held at the morgue.
- Death at home: If the person has been under medical care recently but not in a hospice program, call the police (911), who will determine if the coroner needs to be notified.
- Death in a Hospice Program: Call the hospice nurse for instructions.
- Death in a hospice facility, hospital or nursing home: A doctor will be called to pronounce death.
- In all cases, someone will need to provide the contact information for final disposition of the body (the name and number of the funeral home or name and number of the person in charge of the home funeral).

Who Has the Right to Make Funeral Arrangements in Ohio?

- This right and responsibility goes to the following people, in order:
 - A person you appoint in a written document that meets the requirements of Ohio law (3707.19, passed in 2018). This is called a Disposition of Bodily Remains (see <https://funerals.org/your-rights/state-by-state-rights/state-by-state-assigning-an-agent-to-control-disposition/>)
 - Your surviving spouse
 - Your only child or, if you have more than one, all of them collectively
 - Your parent or parents
 - Other next of kin
 - Your guardian of the person, if you had one at the time of your death



Funeral Arrangements: General Information

- Compare prices from at least two funeral homes if possible before you need to make arrangements. This allows you to consider options without time constraints, creates an opportunity for family discussion, and lifts some of the burden from your family.
- Remember that you can always supply your own casket or urn.
- Ask for a price list. The law requires funeral homes to give you written price lists for products and services.
- Resist pressure to buy goods and services you don't really want or need. Avoid emotional overspending.
- Laws regarding funerals and burials vary from state to state. It's a smart move to know which goods or services the law requires you to purchase and which are optional.

Common Kinds of Funerals

- Every family is different, and not everyone wants the same type of funeral.
- Funeral practices are influenced by religious and cultural traditions, costs and personal preferences.
- These factors help determine whether the funeral will be elaborate or simple, public or private, religious or secular, and where it will be held. They also influence whether the body will be present at the funeral, if there will be a viewing or visitation, and if so, whether the casket will be open or closed, and whether the remains will be buried or cremated.

“Traditional,” Full-Service Funeral

- This type of funeral, often referred to by funeral providers as a “traditional” funeral, usually includes:
- Preparation of the body for burial.
- A viewing or visitation.
- A formal funeral service at a church or at the funeral provider facility.
- Use of a hearse to transport the body to the funeral site and cemetery.
- Burial, entombment or cremation of the remains.
- It is generally the most expensive type of funeral.

Direct Burial

- The body is buried shortly after death, usually in a simple container.
- No viewing or visitation is involved, so no embalming is necessary.
- A memorial service may be held at the graveside or later. Direct burial usually costs less.
- Costs include the funeral home's basic services fee, as well as transportation and care of the body, the purchase of a casket or burial container and a cemetery plot or crypt.

Direct Cremation

- The body is cremated shortly after death, without embalming.
- The cremated remains are placed in an urn or other container.
- No viewing or visitation is involved, although a memorial service may be held, with or without the cremated remains present.
- The remains can be kept in the home, buried or placed in a crypt or niche in a cemetery, or buried or scattered in a favorite spot.
- Some families choose to divide remains and place in different locations or in jewelry.

Prepaying for a Funeral

- Many people enter into contracts to prearrange their funerals and prepay some or all of the expenses involved. But protections vary widely from state to state.
- Make sure you get copies of all arrangements you make and give copies to family.
- **Questions** to ask if you choose to prepay:
 - What are you paying for? Are you buying only merchandise, like a casket and vault, or are you purchasing funeral services as well?
 - What happens to the money you've prepaid? States have different requirements for handling funds paid for prearranged funeral services.
 - What happens to the interest income on money that is prepaid and put into a trust account?
 - Are you protected if the firm you dealt with goes out of business?
 - Can you cancel the contract and get a full refund if you change your mind?
 - What happens if you move to a different area or die while away from home? Some prepaid funeral plans can be transferred, but often at an added cost.



Cemetery Arrangements

- When you are purchasing a cemetery plot, consider the LOCATION of the cemetery and whether it meets the requirements of your family's religion.
- Other considerations include:
 - What, if any, restrictions the cemetery places on burial vaults purchased elsewhere.
 - The type of monuments or memorials it allows.
 - Whether flowers or other remembrances may be placed on graves.
 - Cost is another consideration. Cemetery plots can be expensive, especially in metropolitan areas.
 - Most, but not all, cemeteries require you to purchase a grave liner, which will cost several hundred dollars.
- Note that there are charges – usually hundreds of dollars – to open a grave for interment and additional charges to fill it in.

Perpetual care on a cemetery plot sometimes is included in the purchase price, but it is important to clarify that point before you buy the site or service. If it is not included, there will be a separate fee for maintenance of the grounds.

Organ and Tissue Donation

- The Ohio Donor Registry was established in July 2002.
- It provides Ohioans the opportunity to give legal consent to be an organ, eye, and tissue donor at the time of death.
- An individual may sign up anytime online at www.donatelife.ohio.gov or, by saying "yes" when receiving or renewing their driver license or state ID at the Bureau of Motor Vehicles.
- Hard copy forms are also included in the Ohio Advance Directives packet is available at www.proseniors.org

Anatomical Gift Programs

- Many of the 7 schools of medicine in Ohio will accept a person's body as a gift to be used in research and teaching.
- The particular aspects of these programs, i.e., application process, cost, time frame, and return of person's remains do vary by school.
- Please contact the individual school to receive details of their program.

Indigent Burial in Ohio

- Until July 1, 2001, the State of Ohio took primary responsibility for burial expenses when someone died without resources.
- Currently the burial or cremation is the responsibility of the township or municipal authority in which the person had legal residence at the time of their death (Section 9.15 of the Ohio Revised Code).
- The local authority is also responsible for providing a stone or concrete marker on which the person's name, age, if known and date of death shall be inscribed.
- The local authority is not relieved of its duty to bury or cremate an indigent person if the person is claimed by family members.

Important Documents in Ohio: Wills

- Your will must be in writing. You must date and sign the will in front of two competent witnesses.
- In your will, you will name an "Executor," which is a person who has responsibility for representing you after your death, and distributing your goods between those listed in your will.
- In the case of multiple wills, the most recently legally executed document will be binding

After Death: Tasks & Benefit Issues

- The process of settling the details of an estate and implementing the will is called the probate process. The legal authority in Ohio is the county probate court in which the person resided. This process may take many months to complete particularly if there are significant assets.
- Social Security is notified electronically after the death certificate is filed with the County Department of Health (Vital Statistics Division).
- Other important contacts include: pension administrators, creditors, potential heirs.
- Some tasks include:
 - Determining income sources and expenses
 - Arranging for payment of outstanding medical and other bills
 - Closing financial accounts and online payments
 - Closing club memberships and subscriptions
 - Notifying the post office
 - Arranging for forwarding of mail

Social Security: Lump Death Benefits & Survivor Benefits

- These may be available to a surviving spouse who meets certain requirements as well as dependent children at the time of the person's death.
 - Lump-sum death payment of \$255 if they meet certain requirements. Survivors must apply for this payment within two years of the date of death.
 - Survivor Benefits: The amount of the benefit is determined by the worker's length of service and amount of payments into the system.
- Surviving family members who think they may be eligible for benefits should contact their local Social Security office, www.ssa.gov, or call 800-772-1213.

Bereavement

- Grieving a death is a PROCESS and takes time.
- Bereavement is the term that we use for that process.
- There are many different types of bereavement groups available. DO NOT hesitate to reach out especially several months after all of the paperwork is finished and the detailed tasks are complete.
- If a person has been under hospice, bereavement services are a benefit for the family for up to a year after the person's death.



[Click here to return to the table of contents.](#)

Chapter 2

2.6 Planning Ahead for Care: If You Are A Veteran

How to Apply for VA Benefits

Services & Benefits for US Veterans

The Dept. of Veterans Affairs (VA) provides a wide range of benefits including:

- Service Related Disability Income & Care
- Education and Training
- Vocational Rehabilitation & Employment
- Home Loan Guaranty
- Dependent and Survivor Benefits
- Medical Treatment
- Life Insurance
- Burial Benefits



Eligibility for VA Benefits

You MAY be eligible for VA benefits if you are a:

- Veteran of any branch of the US Armed Services or a veteran's dependent
- Surviving spouse, child or parent of a deceased veteran
- Uniformed service member
- Present or former reservist or National Guard member

How to Apply for VA Benefits

- The VA has several ways to apply for benefits depending on the veteran's category and status.
- First you need a Military Report of Separation (also known as a DD214). The best way to receive a copy of the DD 214 is via an eBenefits account. Go to www.va.gov and register to receive your records.
- Apply at Local & Regional Offices: VA regional offices can assist veterans in filing the appropriate VA forms. Contact the Ohio Dept. of Veterans Services at www.dvs.ohio.gov or call at 614-644-0898.
- In addition, many VSOs (Veteran Service Organizations) can assist veterans as well by answering general questions and even petitioning on their behalf for services they believe the veteran is qualified to receive. See www.vetsfirst.org and www.veteranaid.org.

VA Income, Pensions & Benefits

Many different categories including:

- Veteran's Disability Pension
- Housebound Veteran's Benefits
- Veteran's Aid and Attendance Benefits
- Surviving Spouse and/or Unmarried children Benefits
- Veteran's Disability Compensation Benefits
- Adapted Housing Grants for Disabled Veterans
- Automobile Adaptive Equipment (AAE) for Disabled Veterans



VA Healthcare — How to Apply for Benefits

- Online: www.va.gov
- Phone: toll-free hotline at 877-222-8387.
- Mail: Fill out an Application for Health Benefits (VA Form 10-10EZ).
- Apply in Person: Go to your nearest VA medical center or clinic. Bring a signed Application for Health Benefits (VA Form 10-10EZ) with you.

VA Health Care Benefits

- ALL enrolled Veterans receive the Department of Veterans Affairs (VA's) comprehensive Medical Benefits Package which includes preventive, primary and specialty care, plus diagnostic, inpatient and outpatient care services.
- Veterans may receive additional benefits, such as dental care depending on their unique qualifications. When you apply for VA healthcare, you'll be assigned to one of 8 priority groups.
- Priority groups are based on:
 - Income level
 - Disability rating from VA
 - Military service history
 - Whether or not you qualify for Medicaid
 - Other benefits you may be receiving (like VA pension benefits)

VA Geriatrics & Extended Care Services in Central Ohio

- Geriatric Patient Aligned Care Team (PACT)/Primary Care Team
- Home Based Primary Care Program (HBPC)
- Palliative Care Clinic
- Community Hospice Care
- Community Nursing Home Care
- Adult Day Health Care (ADHC)
- Homemaker/Home Health Aid Program (H/HHA)
- The Care Coordination/Home Tele-Health Program (CCHT)
- The Spinal Cord Injury and Disorders Clinic (SCI&D)
- Geriatric Evaluation Clinic
- Community Health Nurse
- Respite for Family Caregivers



VA Healthcare Centers in Central Ohio

- Chalmer's P. Wylie Veteran Outpatient Clinic, Columbus Phone: 614-257-5200
- Daniel L. Kinnard VA Clinic Newark Phone: 740-788-8329
- Grove City VA Clinic Phone: 614-257-5800
- Marion VA Clinic Phone: 740-223-8809
- Columbus, Ohio Veterans Center Phone: 614-257-5550
- Zanesville VA Clinic Phone: 740-453-7725

VA Caregiver Support Program

- A series of support groups, educational opportunities and other opportunities for caregivers of a veteran and veterans who are caring for family members.
- Program of Comprehensive Assistance for Family Caregivers (PCAFC) – expansion of benefits to veterans and their families who incurred a serious injury in the line of duty. The family members themselves can be paid to care for the veteran under this program depending on the situation.
- Call the Caregiver Support line at 855-260-3274.
- Locate and find a Caregiver Support Social worker at www.caregiver.va.gov Or in Central Ohio, call 614-388-7482.

VA Death Benefits

- Service-Related Death: VA will pay up to \$2,000 toward burial expenses for deaths.
- Non-Service-Related Death: The VA will pay a limited amount towards both burial and funeral expenses for veterans who die of non service connected circumstances. The amount is higher if the person dies in a VA connected facility. VA burial allowances are flat-rate monetary benefits that are generally paid at the maximum amount authorized by law for an eligible Veteran's burial and funeral costs.
- To Apply: You can apply by filling out VA Form 21-530, Application for Burial Benefits. You should attach a copy of the veteran's military discharge document (DD 214 or equivalent), death certificate, funeral and burial bills. They should show that you have paid them in full.

VA Cemetery Benefits

- ALL veterans are entitled to a free burial in a national cemetery and a grave marker. This eligibility also extends to some civilians who have provided military-related service and some public health service personnel, spouses and dependent children.
- There are no charges for opening or closing the grave, for a vault or liner, or for setting the marker in a national cemetery. The family generally IS responsible for other expenses, including transportation to the cemetery.
- For more information, visit the Department of Veterans Affairs' website at www.cem.va.gov.

VA Grave Marker Benefits

- Memorials are available to all veterans, spouses, and dependent children buried in a national cemetery and will be set without charge.
- For veterans who died before September 11, 2001, markers are available to them, not to the spouse or dependents, for use in other cemeteries unless the grave has already been marked by a private memorial.
- A flag is provided on request for the burial of any veteran. Apply through the VA and pick up at a U.S. Post Office. Family members may wish to purchase a flag case for later display, available through private sources.

[Click here to return to the table of contents.](#)



Chapter 2

2.7 Planning Ahead for Care: The Driving Decision

Realities of Older Drivers

- Fewer accidents compared to rest of population.
- Fewer miles driven.
- Higher percentage of accidents per mile.
- Much higher percentage of injury and death per accident.
- Many older adults are self limiting.
- Accidents/incidents significantly increase around age 75.
- There is a difference in perception between older adults and their children.

Common Driving Challenges with Aging

- Vision - perception-decreases, glare adaptation-decreases.
- Mobility - reaction time-increases, coordination-decreases, stamina-decreases.
- Cognitive Abilities - processing information-slower, decision making-slower.
- Medications - more likely to be taking more or taking incorrectly.

Extra Driving Challenges with Dementia

- Short Term Memory-decreases sometimes sharply.
- Judgment-becomes questionable. Drivers with dementia tend to overrate their driving skills sometimes dramatically.
- Decision Making Ability-decreases sometimes sharply.



Questions for an Older Driver

1. Do other drivers often honk at you?
2. Have you had some accidents?
3. Are you getting lost, even on well-known roads?
4. Are you taking medicine that may cause drowsiness or confusion?
5. Do you have difficulty climbing stairs or walking?
6. Have you fallen and sustained injuries once or more in the last year?
7. Do cars or pedestrians seem to appear out of nowhere?
8. Have family, friends, or doctors said they were worried about your driving?

If the answer is **yes to any** of the questions above, you may want to have your driving evaluated and consider not driving as much or not at all.

Questions for Caregivers-Does Your Loved One?

1. Drive at inappropriate speeds?
2. Respond slowly or not notice pedestrians, bicyclists, and other drivers?
3. Ignore, disobey or misinterpret street signs and traffic lights?
4. Fail to yield to other cars or pedestrians who have the right-of-way?
5. Fail to correctly judge distances between cars correctly?
6. Appear drowsy, confused or frightened?
7. Have had one or more accidents or near accidents in the last 2 years?
8. Drift across lane markings or bump into curbs?
9. Forget to turn on headlights after dusk?
10. Experience difficulty with glare?
11. Find it hard to turn his/her head, neck, shoulders or body while driving or parking?
12. Lack the strength to turn the wheel quickly in an emergency?
13. Get lost repeatedly in familiar areas?

If the answer is **yes to any** of these questions, you may want to explore whether medical issues are affecting your loved one's skills or have their driving evaluated.

What is the procedure for reporting someone who should not drive because of age or because of a medical, physical or vision problem?

(Answer supplied by Ohio BMV 2025)

The Ohio Motor Vehicle laws allow the Registrar of Motor Vehicles to require an Ohio licensed driver to submit a medical statement and/or take a driver license examination upon receiving information giving “good cause to believe” that the driver is incompetent or otherwise incapable of safely operating a motor vehicle. (ORC 4507.20)

To take action on a request received from a law enforcement agency or court, we require that the agency or court has had personal observation of the subject’s driving or personal contact with the driver. We cannot take action on the recertification request if it is based solely on the person’s age or hearsay. The Bureau will also take action on a written and signed request submitted by a relative, friend, neighbor, etc. However, we are required to first conduct an investigation to determine if there is sufficient cause to require a medical statement and/or driver license examination.

Legally, we must inform the driver who is the subject of our investigation or recertification procedures of our source of information. Therefore, before an investigation or any other action is taken on request received from a family member, neighbor, friend, nurse or social service agency, we must receive permission to use the letter writer’s name as our source of information. **However, information received from a physician is considered confidential.**

If someone or a doctor would like to submit a written request to the Bureau to have a driver recertified for driving privileges, you may send or fax the letter to the Ohio Bureau of Motor Vehicles.

Attention:
Driver License Special Case Section/Medical Unit
P.O. Box 16784
Columbus, Ohio 43216-6784
Fax: (614) 752-7271, Attention Medical Unit



Some Other Suggestions

- Consult with the doctor or other medical provider. There may be a health problem, or medication that is affecting a person's ability to drive. Request a referral from a person's doctor to:
 - The Ohio State University Rehabilitation Driving Program, for a driving evaluation. The program includes a comprehensive evaluation, driver simulation, and driving recommendations.
Some insurance plans will cover all or a portion of the fee. You may also call the OSU program at 614-293-2001 to request information or visit the website: www.medicalcenter.osu.edu.
 - The Grady Memorial Hospital Driver Rehabilitation for the Instruction and Vehicle Education Program at 740-615-2660 or www.ohiohealth.com/grady
- If you would like to "brush up" your driving skills, contact the AARP 55 Alive, Driver Safety Program 888-227-7669 or www.aarp.org. These driver education classes alert older drivers to changes in traffic, their own changing physiology, and current regulations. Some insurance companies offer discounts for completing the courses. AARP also has many written materials about the driving decision.
- Car Fit is a program designed assess older drivers to make sure their cars are set up for the best possible and safest conditions to continue driving. The COAAA coordinates Car Fit for the State of Ohio. For more information see, www.coaaa.org or www.car-fit.org.
- Check with the Association for Driver Rehabilitation, www.driver-ed.org and the Easter Seals–Project Action <https://www.projectaction.com/> for information on referrals and other transportation alternatives.
- Download a copy of the Central Ohio Transportation Guide from www.coaaa.org under "Resources" or call 800-589-7277 to request a hard copy.

Click here to return to the table of contents.

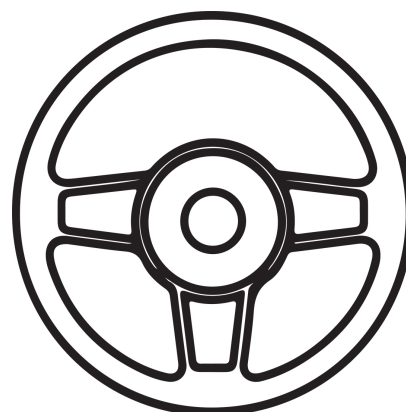

CHAPTER 3

Navigating the Healthcare System

Section 3.1

Advocating with
Healthcare Providers (p.50)

Section 3.2

In the Hospital Setting (p.54)

Section 3.3

Palliative vs. Hospice Care (p.58)

Section 3.4

Finding and Managing
Care at Home (p.62)

Section 3.5

Finding and Managing Care in a
Long Term Care Facility (p.74)

Section 3.6

Avoiding Abuse, Neglect
and Exploitation (p.77)

CHAPTER 3



Chapter 3

3.1 Navigating The Healthcare System: Advocating with Health Care Providers

Visits with Health Care Providers

- Get ready for your appointment.
- Call the office and see if they are running behind (more than 15 minute wait is not acceptable).
- Share all relevant information with your provider.
- Get the right information. Ask questions!
- Write it down! Have a notebook you take notes in by date and visit.

Your RIGHT to Privacy

- Health Insurance Portability & Accountability Act (HIPAA) was passed in 1996. It says that providers may not give information about your health situation to others without your authorization.
- A health care provider has to ask you to clarify with whom they can discuss your protected health information. You will sign this form every time you get medical treatment.
- A health care provider may give you a number or a code to give out to those you want to receive information about your status.
- However, a health care provider **MAY** discuss information with your personal representative (legal guardian or power of attorney for health care) **WITHOUT** any additional authorizations.



Your RIGHT to Understand Medical Terms

- Medical terminology is not always easy to understand.
- Not knowing a term or word is perfectly normal.
- You have the right to have procedures & medical instructions explained to you in plain English. If English is not your first language, you have the right to request an interpreter at no cost to you.
- Medicines are often called several different names depending on if they are brand name, generic, or extended release.
- Check medicines and other health terms on www.medlineplus.gov.
- DO NOT HESITATE TO ASK!

Your RIGHT to Access Your Own Medical Records

- Medical records are now computerized and so they should be completely accessible to you and different providers who see you.
- Most systems call this “My Chart.” There is a universal system that covers all of your records no matter what provider. This is called the EPIC system.
- You absolutely have the right to read and access all of your records. You also have the right to receive hard copies but a provider **can** bill you a print fee for these.
- In order to access a family member’s records, they would either need to give you written permission OR you would need to be a Health Care Power of Attorney or other legal decision maker for that person.



Your RIGHT to Receive Timely Billing Information

- You have the right to request estimates of the cost of services as well as what the out-of-pocket cost may be after your insurance pays their amount. Make this request before a procedure!
- Watch out for the “facilities fee” that is charged by some providers. You may be able to avoid paying that charge by choosing to get a procedure by your same provider at a different location. Facilities fees are mostly paid out of pocket by the patient.
- Only pay a bill after your health insurance pays—and only the amount they tell you to pay.
- Reminder: Medicare only sends statements quarterly but you can check them online immediately.
- You always have the right to request a monthly billing plan to help cover your part of costs.



Your RIGHT to Get a Second Opinion

- Most health insurance providers will pay for you to get a second opinion of a diagnosis, suggested treatment or prognosis.
- Ask what the procedure is to get a second opinion before you make the appointment with the provider.
- Get all suggestions in writing.



Your RIGHT to Appeal Denials or Services or Care

- You always have the right to appeal a denial.
- Ask for the denial in writing if someone is telling you a service or a stay is denied.
- Follow the written rules to appeal.
- Usually this involves signing your name that you wish to appeal and returning the denial.
- Keep a copy of the appeal paperwork for yourself.



Your RIGHT to Complain When There are Problems with Care

- All health care providers have a system which accepts complaints about care and follows up on them.
- Sometime this function is called a health care advocate, an ombudsman, a mediation service or a quality improvement department. Ask about what the health care provider calls this function in its organization.
- If you make a complaint, always do it in writing and keep a copy for yourself.
- You have a right to a written follow up to all complaints about care for yourself or a loved one.



[Click here to return to the table of contents.](#)

Chapter 3

3.2 Navigating the Healthcare Maze: In The Hospital Setting

How to Watch for Someone's Best Interest in the Hospital

- Be an advocate!
- As a caregiver, YOU are often in the role of spokesperson for hospitalized person.
- You are in the best position to inform the hospital staff of the person's likes and dislikes.
- Often you are the one who communicates how he/she really feels and what he/she would want done.



Issues to Consider-The Hospital Schedule

Questions To Ask:

- Does the hospital use its own doctors (called hospitalists) who then report back to your doctor(s) or will your doctor(s) be visiting?
- When do the doctors usually visit patients on your floor?
- What are the hospital's visiting policies? (may be more restricted at times)
- What are the hospital's meal policies/choices and times of meals?
- When does the staff change shifts on that floor?
- What staff might be visiting the room? Can you request a visit by pastoral staff, therapy staff etc.?
- How often do they allow you to shower or change the linens?
- Do they expect you to call when you use the restroom?
- Is there WIFI and if so, how to access it?

Issues to Consider: Personal Belongings

- Think about what belongings to have with you or your family member. Valuable rings, jewelry and electronics might not be a good idea.
- Pay particular attention to a person's glasses, hearing aids, and dentures.
- Label all belongings.
- Take pictures of belongings and ask if the hospital keeps an inventory list for patients.



Issues to Consider: Medications in the Hospital

- MAKE SURE the hospital has an updated medications list so that the person can continue to take regular medications while there.
- Some medications, particularly pain medications can be prescribed in a manner, called PRN, which can allow the patient to have some flexibility to request pain or nausea relief.

Issues to Consider: Visitors and Students

- You may wish to limit the number and frequency of visitors your loved one receives. Visitors sometimes do not understand how tiring their visits can be for someone who is ill.
- On the other hand, if your relative is lonesome and wants visitors, you may have to arrange for people to come and see the person in a manner that provides both pleasure and comfort.
- You can also express your preferences to limit the number of medical/health care students involved in the care of your loved one.

The Role of the Discharge Planner

- “Discharge Planners” or “Case Managers” may be social workers or nurses.
- Their role is to create a transition plan for after the person leaves the hospital.
- Their role begins the day of hospital admission.
- Their role is vital to enable the patient to make a full recovery.
- Discharge Planners will:
 - Share information between the patient, caregiver and medical team.
 - Meet with patient, and caregiver to gather information.
 - Communicate with the medical team and the patient’s insurance.
 - Arrange for medical equipment, community support services, home health care or transition to a care facility.



Information to Share with The Discharge Planner:

- How was the person functioning prior to hospitalization – independent? Or needing assistance? Having cognitive impairment?
- Who is involved in the person’s care (if not living independently)?
- Who is the primary caregiver(s) (family, friend, neighbor, paid caregiver)?
- Does the person have a case/care manager in the community? – What is their contact information?
- What assistance is being provided currently?
- What medical equipment is the person typically using? What is the person’s living arrangement? (alone, with family or others).
- Are there accessibility concerns in the home? (stairs, narrow doorways or halls).
- Are there unmet needs that would impact the person’s recovery?
- Are there social needs such as housing, utility disconnections, food insecurity?
- Are there service needs? (meals, housekeeping, personal care, medication management).

Prior to Hospital Discharge to HOME--A Discharge Planner Will:

- Review medication list – reconcile between pre/post hospital lists, obtain new prescriptions.
- Discuss new medical equipment needs including oxygen, verify that items have been ordered or obtain prescriptions.
- Obtain training on any special care required such as wound dressings, feeding tubes, or catheter care.
- Verify that referrals have been made for home health care including nursing, physical/occupational/speech therapies, or hospice care, get the name of the home health agency that will be providing care.
- Make referrals for community supports to address unmet needs such as home-delivered meals, personal care aides, homemaking services, medical transportation.
- Determine what medical follow up appointments are needed.

Hospital Discharge to a Facility

- Person is medically stable for transition from acute to rehabilitative care.
- There should be planning for continuity of care to aid person's recovery.
- Requires clarification between care settings of the person's health status and capabilities.
- Type of facility is determined by the person's care needs:
 - Nursing Facility Rehabilitation sometimes called *Sub Acute Care*
 - Long Term Nursing Facility or Assisted Living Placement

Helpful Websites:

- www.age.ohio.gov
Ohio Long-Term Care Guide and Facility Finder
- www.medicare.gov
Nursing Home and Home Health Care Compare Tools

Considerations in selecting a care facility:

- Specialized care needs ex. onsite dialysis, ventilator care, dementia care.
- Quality indicators like recent state inspection report.
- Tour and observe cleanliness, staff/resident interactions, residents' appearance, activities.
- How far in distance from family-- for frequent visitation.

Click here to return to the table of contents.

Chapter 3

3.3 Navigating The Healthcare System: Palliative vs. Hospice Care

Palliative Care- General Definition

- Palliative care is specialized medical care that focuses on providing patients RELIEF FROM PAIN AND OTHER SYMPTOMS OF A SERIOUS ILLNESS, no matter the diagnosis or stage of disease.
- Palliative care aims to improve the quality of life for both patients and their families.
- It is like a big umbrella with lots of types of care falling beneath it.
- Technically, Hospice Care is a particular type of Palliative Care.
- However the term “Palliative Care” has started to be used to refer to care delivered in a healthcare setting where the person still wishes to receive care towards a cure of disease or illness.



Timing of Treatment

Palliative Care

- There are no time restrictions. Palliative care can be received by persons at any time, at any stage of illness whether it be terminal or not.

Hospice

- A person must generally be considered to be terminal or within six months of death to be eligible for most hospice programs or to receive hospice benefits from Medicare, Medicaid, and other insurance carriers.

Place of Treatment

Palliative Care

- Palliative care teams are made up of doctors, nurses, and other professional medical caregivers, often AT the health care facility where a person is receiving treatment for an illness or condition. There are some in-home palliative care providers as well.
- These individuals will administer or oversee most of the ongoing *comfort-care* that the person will receive.

Hospice

- Hospice care is administered in the person's home or place of residence (even in a long-term care facility).
- Hospice treatment often relies upon family caregivers, as well as a visiting hospice nurse and other professionals to keep a person as comfortable as possible.
- While a hospice program can provide care in a hospice facility, or a hospital, this is NOT the norm.

Type of Treatment

Palliative Care

- Since there are no time limits on when a person can receive palliative care, it acts to fill the gap for persons who want and need comfort at any stage of any disease, whether terminal or not.
- In a palliative care program, there is no expectation that life-prolonging therapies will be avoided or stopped.

Hospice

- The concentration is on comfort rather than aggressive disease treatment.
- Persons on hospice elect to forego or stop extensive life-prolonging treatments and concentrate on staying comfortable in the time the person has left.



Hospice Care – Eligibility

- Under Medicare, and most other insurance, people are eligible for the Hospice benefit if they are assessed to have a life expectancy of six months or less if the disease runs its normal course.
- The assessment for Hospice service is FREE.
- Eligibility can be renewed if death does not occur in a six-month period. Some illnesses like Alzheimer’s disease have a list of symptoms that count as a terminal diagnosis if they are present.
- Some indications that people may meet these criteria include:
 - Progressive decline in functional status despite curative treatments
 - Frequent hospitalizations or emergency room visits
 - Repeat or multiple infections
 - Increased or uncontrolled pain
 - Progressive/profound weakness and fatigue
 - Shortness of breath with or without oxygen
 - Dependency (needs assistance in activities of daily living)
 - Alterations in mental status
 - Weight loss

Typical Kinds of Services of Hospice

- Generally someone must enroll in a Hospice program which is listed as a provider for either Medicare or the insurance company. Important: Medicare and other insurance companies will still pay for covered benefits for any health problems that aren’t related to the terminal illness, such as care for an injury.
- Medicare and most insurance cover the following hospice services:
 - Doctor services and Nursing care
 - Medical equipment (such as wheelchairs or walkers)
 - Medical supplies (such as bandages and catheters)
 - Drugs for symptom control or pain relief
 - Hospice aide and homemaker services
 - Physical, occupational therapy, & Speech-language pathology services
 - Social worker services & Dietary counseling
 - Grief and loss counseling for person and the family
 - Short-term inpatient care (for pain and symptom management)
 - Short-term respite care
 - Any other Medicare (or insurance)-covered services needed to manage pain and other symptoms related to the terminal illness, as recommended by the hospice team.

What Is NOT Generally Covered in Hospice?

When someone chooses hospice care, they have decided that they no longer want care to cure their terminal illness and/or their doctor has determined that efforts to cure the illness aren't working. Medicare and most insurance will not cover any of the following once someone chooses hospice care:

- Treatment intended to cure the terminal illness.
- Prescription drugs to cure the illness (rather than for symptom control or pain relief).
- Care from any hospice provider that wasn't set up by the hospice medical team.
- Room and board---Medicare and other insurance doesn't cover room and board if someone gets hospice care in their home or if they live in a nursing home, assisted living facility, or a group home.
- Care in an emergency room, inpatient facility care, or ambulance transportation, unless it's either arranged by the hospice team or is unrelated to the terminal illness or condition.

[Click here to return to the table of contents.](#)



Chapter 3

3.4 Navigating The Healthcare System: Finding and Managing Care at Home

Why Choose Care in the Home?

- Studies show that most people desire to live in their own homes as long as possible.
- “Home” may be a residence they own or rent as an individual, or a “group” living arrangement (like a family).
- Implies that the person will be supported where they choose to live as their functional needs change over time.

Types of In-Home Services

- Meal Programs
- Transportation Services
- Respite Care
- Adult Day Health Care
- Home Health (or Personal Care Aide)
- Companions
- Homemakers
- Medic Alert Programs
- Minor Home Modification
- Telephone Reassurance Programs
- Nursing Care
- In Home Therapies
- Case Management/Care Coordination

For a description of these services, see p. 10.



Paying for In-Home Care

- Medical Insurance (i.e. Medicare)-These tend to pay for medical assistance and needs. Most are very short term and tied to a particular illness, injury or hospital stay. They DO NOT pay for ongoing care in the home.
- The cost VARIES WIDELY by the type of service needed, the intensity and the type of provider hired (i.e. medical care vs. non-medical care).
- Though there are some programs which can help pay for care in the home, most in home care is purchased PRIVATELY.

Programs that Can Help Pay for In-Home Care

County Senior Levy Programs

- Some counties have senior tax levies that can assist with paying for services. Many operate on a sliding fee scale.
- All counties in COAAA service area have local levies except Fayette County.
- Many county levy programs offer a care or case manager to assist in navigating the various services.

Medicaid Waiver Programs (i.e. PASSPORT, Next Gen My Care)

- Ohio has several programs which are designed to provide home and community based care to those who would otherwise be living in a long term care facility on Medicaid. The largest of these is called PASSPORT. The PASSPORT program serves people who are:
 - Age 60 or older & financially eligible for Medicaid institutional care.
 - Frail enough to require a nursing home level of care.
 - Able to remain safely at home with services. PASSPORT generally will not be able to fund 24 hour hands on care.
- Another program very similar to PASSPORT but for people under age 60 is called the Ohio Home Care Waiver.
- The Next Gen My Care Ohio Waiver is a program which has similar criteria but serves those who are eligible for BOTH Medicare and Medicaid. They are assigned a managed care organization to coordinate their care needs. Starting in 2026, this program is going statewide.
- For more information on these programs, go to www.medicaid.ohio.gov.

Programs that Can Help Pay for In-Home Care

Long Term Care Insurance

- Separate insurance policies designed to cover the costs of long term care. These are not regulated or standardized in Ohio.
- They tend to be more expensive as a person gets older.
- For more information, go to the Ohio Department of Insurance at www.insurance.ohio.gov

Veterans Administration

- Programs for those veterans who have service-connected disabilities and financial needs. Go to **p. 40-43** of this manual for more information.

Possible Advantages of Hiring an Agency for In-Home Care

- The agency will conduct an assessment by a professional and develop a plan of care to monitor your relative's progress.
- The agency will probably be able to provide more than one type of assistance if your relative requires more kinds of care.
- The agency will communicate with your doctor and alert him/her to any problems which may develop.
- The agency will pay employee salaries, taxes, insurance and other benefits. They will bill Medicare, Medicaid and Insurance if applicable.
- The agency will provide background checks, supervision and training to employees.



Possible Advantages of Hiring an Individual for In-Home Care

- The kinds of assistance provided may be more flexible.
- The hours may be more flexible.
- It may be less expensive if paying privately (i.e. no Medicare, Medicaid, or Insurance).
- The family member receiving assistance may be more accepting of an individual rather than an agency.
- The family may prefer direct supervision of the individual(s) in the home.
- Always check references & background if hiring an individual.

STEPS in Hiring and Supervising a SELF-EMPLOYED HOME-CARE WORKER:

Step 1: Decide What Type of Assistance You Need

Step 2: Create a Job Description

Step 3: Locate Workers

Step 4: Interview Workers

Step 5: Background Check and Check References

Step 6: Create and Sign a Work Agreement

Step 7: Orient the Worker to Your Home/Family Member

Step 8: Supervise the Worker

Step 9: Pay the Worker, Pay Taxes and Keep Records

Step 10: Red Flags That There May Be a Problem with Care and Termination



STEP 1: Decide What Type of Assistance You Need

Suggestion: Take a good look at your situation and try to decide what kind of assistance you need. See the questions below. Many times, family and friends are either working or not available to fulfill all of the needs of a family member. The questions below can help you to pinpoint what types of assistance a home care worker can provide and how often. If the answer to any of these questions is no, fill in who is providing this assistance currently. How sustainable is this arrangement?



Self-Care Concerns--Is your loved one able to:

- Do grocery shopping independently?
- Prepare his/her own reasonably nutritious meals?
- Bathe and dress without help, look presentable and seasonally appropriate?
- Keep his/her home orderly and do housekeeping without assistance?
- Handle emergency situations and know what to do to get help in a medical emergency at home?
- Manage his/her own finances, pay bills and handle medical forms?
- Manage without frequent falls/injuries?

Social Concerns--Does your loved one have:

- Ongoing contact with other people on a regular basis?
- Any social life outside the immediate family?

Physical Condition Concerns--Does your loved one:

- Have serious health problems?
- Currently receive treatment for health problems?
- Take medications (if so, how many and what kind)?
- Take medications without being reminded?
- Have a disability, making it difficult to get around in his/her own home?

Emotional/Mental Condition Concerns--Does your loved one:

- Become very forgetful or confused about time and dates, where he/she is and what he/she should do?
- Have frequent or unexpected mood changes for no apparent reason?
- Complain about being bored and lonely?
- Cry or seem sad a great deal of the time?

NOTES:

STEP 2: Create a Job Description

May include the following:

- A list of the tasks/services that you will need assistance with and expect the care worker to perform. Be as specific as possible.
- Experience, skills, education, qualifications etc. preferred or required.
- Any special medical or adaptive equipment you may use.
- Days & times you will need assistance, including the number of hours to be worked, the time to report to work and the time to leave work. Agree on times and frequency of breaks.
- Preferred salary expectations/pay range offered.
- Include any concerns of the care recipient such as incontinence, confusion, behaviors.
- Transportation related concerns/expectations.

STEP 3: Locate Workers

- Use your network of friends in your search. Sometimes the best help comes from a friend or neighbor. They just might know of the perfect person, have used someone in the past or have heard of someone perfect for the job.
- Contact your local church, senior center, community center, community college and disease associations for lists of persons who may be available for what you need. There are also places that have public bulletin boards and/or list job opportunities on their website. List your available position with every organization possible.
- Place an ad in the local paper, newsletter or internet site that has employment ads. Be as specific as possible but do not list your address. Just include a phone number or email address and screen those who answer carefully.



STEP 4: Interview Workers

- Develop standard questions to ask all of the care workers that you will interview.
- Include the care recipient in the interview process if possible.
- Review job description in detail. Be specific about what duties you expect the care worker to perform and how they should be completed.
- Inquire about the care worker's back-up plan in the event of their illness, family emergency, vacation etc.
- Inquire about past home care experience, work history, certifications, and trainings.
- Request references, credentials, driving record, auto insurance to contact and verify after interview.
- Inquire about experience with older adult conditions and diagnoses.
- TRUST YOUR INSTINCTS. If something feels wrong, it probably is. Don't hire anyone that you would not enjoy being with yourself.

SAMPLE Interview Questions for Home-Care Worker

- Are you certified and/or licensed in your profession? NOTE: This depends on what type of person you are hiring. Obviously health care professionals like nurses and therapists should be licensed; but aides who do personal care can be licensed in the state of Ohio as State Tested Nurse's Aides (STNA) and you can ask about that.
- What specialized training have you had?- list areas like CPR/First aid, dementia training etc.
- How long have you been doing this type of work?
- Have you received any awards or accommodations for your work?
- Are you willing and able to perform all job duties?
- Do you have transportation to our location?
- When are you available to start?
- What is your hourly rate?
- Are you available to travel with care recipient, if necessary? (List where)
- Ask questions about issues that may impact care: Do you smoke, wear perfume, have any infectious illness? All of these may be appropriate depending on what illnesses the care recipient is experiencing.
- If language is an issue, ask if the worker speaks the language of the care recipient.

STEP 5: Background Checking Self-Employed Home Care Workers in Ohio

- Ohio Bureau of Criminal Identification & Investigation (BCI&I) 877-224-0043
- WebCheck – electronic fingerprinting system, can do both State of Ohio and National (FBI) background checks.
- For more information and to locate a WebCheck agency go to: www.ohioattorneygeneral.gov/backgroundcheck/. Fees vary slightly.
- Approximate cost for the combined Ohio and National checks is \$60.

Request and Call an Applicant's References

- In addition to calling former clients, the individual or family can call hospital or nursing facility discharge planners, doctors, and community home care programs to get their input if they have had contact with the worker.
- SAMPLE Reference Questions For Care Worker's Former Clients and their Families:
 - How long have you known the care worker?
 - How reliable, dependable and trustworthy was the care worker?
 - How well did the care worker communicate with you and the client?
 - Did you have any problems or concerns with care worker?
 - Would you use the care worker's services again?
 - How well did the care worker perform in an emergency and/or conflict situation?
 - What are the care worker's strengths and limitations?

STEP 6: Create and Sign A Work Agreement

- Once you have decided on a care worker, develop a written work agreement. This will help formalize your relationship and outline your expectations. It can be revised at any time. A thorough work agreement will help the care worker understand what is required of them and be prepared to do it.
- Include detailed descriptions of the tasks to be completed, hours and days of work, rate, and schedule of payments, cancellation, and absence arrangements, start date, acceptable and unacceptable behaviors, and grounds for termination.
- Unacceptable behaviors, such as tardiness, absenteeism etc.
- Amount of notice you or your caregiver must give to end your contract or arrangement.
- Cancellation/absence arrangements and back-up plan.
- Obtain identifying information about care worker such as: address, contact numbers, social security number and date of birth.

STEP 7: Orient the Worker to Your Home/Family Member

- Schedule a home orientation prior to the care worker's first day of work to allow the care worker the opportunity to become acquainted with you and your family members.
- Practice any emergency procedures that may be necessary to ensure your relative's safety.
- Provide specific written instructions on how to seek medical care and other emergency assistance.
- Help the care worker understand how to communicate with you or your family members. Stress the importance of both verbal and nonverbal responses.
- Provide a primary and backup phone number for them to call if there are problems.
- Familiarize the care worker to any unusual symptoms associated with you or your family member's disability.
- Show the care worker the locations of smoke detectors, fuse box, fire extinguishers, standard first-aid kit and a list of emergency telephone numbers including emergency medical service/ambulance, pharmacy, family members and poison control. Keep a list by each telephone.
- Show the care worker where to find medication list including type of medication, purpose of medication, dosage, times of day when taken and any special requirements.
- Show the care worker where the household supplies are kept and how to operate appliances and other household equipment.
- Show the care worker what rooms can and cannot be accessed in the home (if applicable).
- Make sure the care worker knows of any dietary restrictions, house rules and personal preferences.
- Inform care worker of family and friends who may visit care recipient and who should not.

STEP 8: Supervise the Home Care Worker

- Clearly define your expectations.
- Treat each other with respect.
- Ask for feedback from both worker and care recipient.
- Maintain a log to track the hours and days worked.
- Address potential problems with the worker immediately.
- Provide prompt feedback to the worker about his/her performance.
- Have regular meetings to discuss concerns that you or your care worker may have regarding the care being provided or the care arrangements.

STEP 9: Pay the Worker, Pay Taxes and Keep Records

Pay the worker an agreed upon pay rate and DO NOT use cash. Use a time log to document the hours the person has worked. Have the person and care recipient sign off on the time log. Use either a check or bank transfer to pay the person. These are traceable and documentable for tax purposes.

US Tax Rules

- If you pay more than \$2,800 in a calendar year (2025) to someone who comes into your home, you are required to pay Federal Medicare and Social Security tax for that individual.
- You may use form 1040 to file and pay the tax. More information is found in the IRS Guide #926: Household Employer's Tax Guide which is downloadable at (www.irs.gov).
- You may also be required to pay Local and State taxes so check on these with Ohio Department of Taxation at www.tax.ohio.gov and your local community.

Workers Compensation

- Worker's Compensation coverage is required for full-time or part-time domestic workers employed inside or outside of your private residence. Domestic household employers who pay workers \$160 or more in a calendar quarter (3 months) must have workers' compensation coverage, if the worker does not have his/her own business or own workers' compensation insurance.
- For more information contact the Ohio Bureau of Worker's Compensation at 800-644-6292 or <https://info.bwc.ohio.gov/>

Homeowner's & Auto Insurance

- Check your own (or your older relative's) homeowner's insurance and confirm that there will be coverage if there is an accident or injury in the home.
- If the person will be driving an older family member, check that the person has auto liability insurance.



Federal Tax Deductions/Credits for Home Care

Under certain circumstances, the caregiver can qualify for income tax benefits that offset their expenses in providing care to a family member. These tax “breaks” include claiming the person in care as a dependent and receiving a “dependent care credit.” For the older person, certain tax credits also apply and some expenses are deductible.

When a Person Qualifies as a Dependent for Income Tax Purposes, Five requirements must be met:

- The person does not earn more than a specified amount of gross income, adjusted each year to match the personal exemption.
- The taxpayer provides more than one-half of the person’s support.
- The person has one of the following relationships with the taxpayer: child, sibling, parent, grandparent, aunt, uncle, niece or nephew, in-law, grandchild, great- grandchild, stepparent or child, OR the person lived in the taxpayer’s home during the entire tax year and is a member of the taxpayer’s household.
- The person did not file a joint return with a spouse.
- The person is a citizen, national or resident of the United States, Canada or Mexico.

Tax Credit for an Elderly or Disabled Person

- A tax credit may be available to persons who are 65 or over or who are permanently or totally disabled. Special rules and procedures apply for calculating the amount of the credit. See **IRS Guide #554 Tax Guide for Seniors (2025)**. The website is www.irs.gov.

What Can Be Deducted for Income Tax Purposes?

- If a person can be claimed as a dependent and the caregiver itemized expenses on his/her tax returns, the caregiver may deduct medical expenses that exceed 7.5% of his/her adjusted gross income (2025).

Other Possible Deductible Care Expenses

- Improvements or additions to the home for medical purposes (to the extent that they do not increase the value of the property).
- Expenses of a guide dog.
- Lodging while away from home for a medical reason (meals not deductible).
- Medical insurance (long term care and supplemental policies-with limitations).
- Nursing home expenses (with type of care limitations).
- Transportation costs to take a person to medical care.

STEP 10: Red Flags That There May Be a Problem with Care

- Unanswered telephone calls or a constant busy signal at home of care recipient while care worker is on duty/shift.
- Late arrivals, early departures, last minute cancellations.
- Significant decline in cleanliness of home.
- Presence of other people in the home.
- Frequent complaints on the part of the care recipient or troubling changes in his/her behavior.
- Materials in the home which are missing or damaged with no reasonable explanation.
- Questioning reports/concerns from neighbors, friends or others who are observing the situation.

If You Must Make the Decision to Terminate a Worker:

- Give the person a written notice.
- Document (write down) your reasons.
- Take back keys or change passcodes if you have given them to the worker (i.e. garage door codes).
- Ask the worker to delete care recipient's phone number and family members' phone numbers from their mobile phones. In some situations, it may be necessary to block numbers of previous employees.



[Click here to return to the table of contents.](#)

Chapter 3

3.5 Navigating the Healthcare System: Finding & Managing Care in a Long-Term Care Facility

Over 12 million persons of all ages require some type of help with long term care. More and more, families are able to provide care at home. However, sometimes, your loved one's care requires more attention than you can safely or affordably give at home, and your loved one needs to move to an environment which can meet those needs. **When this happens, the type of care you are providing will change but your family member still needs you as much as ever.**

Time to Consider Care Facility Placement When...

- **The person** receiving care has dementia that produces unpredictable behavior including wandering.
- **The person** receiving care has incontinence.
- **The caregiver** is unable to safely lift and transfer the person.
- **The caregiver** is experiencing sleep deprivation.
- **The caregiver** has health problems.
- **The caregiver** is experiencing resentment.
- **The caregiver** is experiencing other significant life stressors.

Choosing a Care Facility:

- **There are many different kinds** of facilities that meet different needs. The most common are assisted living facilities and nursing facilities.
- Payment options vary **widely** depending on the type of facility. Ask clarifying questions about fees and payment sources when visiting.
- **Locate the facilities** in your area by reviewing Ohio's Long Term Care Consumer Guide and Compare areas <https://aging.ohio.gov/>
- **Choose a facility nearby** so family and friends can visit frequently.
- **Visit as many facilities** as you can at different times of the day to observe staff and activities.
- **Ask lots of questions** about the care and observe carefully what residents are doing while you are visiting.
- **Talk to families**, friends and others who have had **recent** experience with particular facilities.

Questions to Ask?

- Is the facility licensed and by whom?
- Is the facility Medicare or Medicaid certified?
- What services and supplies are included in the daily rate?
- How are roommates selected? (if applicable)
- How are complaints handled?
- What is the staff-to-resident ratio on all shifts?
- Are therapies available if needed? At what additional cost?
- How is pain managed?
- What are visiting hours? Are there restrictions?
- Who is available to answer concerns "after hours?"



Resident Rights in a Care Facility

- Be free from physical, verbal, mental, and emotional abuse.
- Be free from physical and chemical restraints.
- Be treated with dignity and respect.
- Receive adequate and appropriate care to meet your medical, social, and emotional needs.
- Receive itemized bills for services rendered.
- Be informed in advance of the charges for services.
- Participate in planning own care.
- Voice grievances and problems.
- Control who has access to medical records.
- Be free from financial exploitation and to manage own personal affairs.
- Receive reasonable notice before a room or roommate change.
- Receive notice of any transfer, discharge or discontinuation of services and be given information about any available appeal process. The resident should receive these rights in writing upon admission!

Watch Out for the 7 Most Common Problems in Care

1. Not being taken to the bathroom when needed can lead to incontinence.
2. Not getting enough fluids can lead to dehydration.
3. Not getting enough to eat can lead to malnutrition.
4. Improper grooming can lead to poor hygiene.
5. The lack of preventative skin care can lead to pressure sores.
6. The lack of range of motion exercises can lead to loss of mobility.
7. The lack of encouragement to retain independence can lead to loss of function.

Getting the Care You Want

- Attend or request Care Planning Conferences with facility.
- Keep open communication with facility staff and write everything down.
- Write letters to the administrator if you have an ongoing issue.
- If concerns continue, contact the Long Term Care Ombudsman at www.aging.ohio.gov and phone number 800-282-1206.
- To make a formal complaint, contact the Ohio Dept. of Health at www.odh.ohio.gov and phone number 800-342-0553.

What to Bring to Visits

- Food – that special something that will not usually be on the facility menu – chili dogs, deviled eggs, pizza, KFC, limburger cheese, onions!
- Music – whatever the person enjoys
- Photo albums, home videos
- Movies, sports videos
- Books, magazines
- Animals (check facility policy on animal visitation)
- Be Creative!



Tips for Outings from the Facility

If you plan to take your loved one on outings consider the following:

- It is important to gauge your loved one's endurance, especially if they have not had any recent outings.
- Get input from facility staff.
- Help your loved one mentally prepare for a trip. Begin discussing it well in advance. He/she may need to build up stamina with short trips.
- Be sure clothing is practical and appropriate for the weather.
- Plan for handling incontinence.
- Obtain any medications needed while the person is out of the facility. Take extra doses if possible.
- Be sure you are capable of safely transferring your loved one.
- Be sure you understand how to use any required medical equipment.

Click here to return to the table of contents.

Chapter 3

3.6 Navigating the Healthcare System: Avoiding Abuse, Neglect, and Exploitation

- Abuse can take many forms—physical, sexual, psychological, and financial exploitation, and can include neglect. The issue of abuse and neglect cuts across all racial, ethnic, socioeconomic, geographic, and relationship boundaries. A national study estimates that one in every 25 older Americans is a victim of abuse.
- Abuse, neglect, and exploitation can come from both family and friends who are providing care and from those who are paid to provide care.
- While most caregivers intend no harm, abuse and neglect happen more often than we think. Caregiving requires health care and emotional support, which can be demanding work. Caregivers perform these tasks under working conditions that can be stressful, and caregivers may receive little support from others.
- They may also find themselves the target of abuse from the individual or other family members. As stress increases, so does the potential for abuse. For whatever reason it occurs, abuse and neglect are harmful.

Recognize the Warning Signs:

- Changes in the older adult's physical appearance.
- Changes in the older adult's personality.
- Observing a dominating or threatening care giver.
- Observing changes in the older adult's home environment.



Different Types of Victimization

- **Physical abuse:** Inflicting or threatening pain or injury, or depriving a person of basic needs.
- **Emotional abuse:** Inflicting mental pain or distress through verbal or nonverbal acts.
- **Sexual abuse:** Touching, fondling, intercourse, or any other sexual activity with an adult, when the adult is unable to understand, physically forced, threatened, or unwilling to consent.
- **Financial Exploitation:** Illegal taking, misuse, or concealment of funds, property, or assets.
- **Neglect by others/self:** Failure by those responsible to provide food, shelter, health care, or protection. Also includes the failure to perform essential self-care tasks, which can lead to illness or injury.

Prevention Of Victimization by Family and Friends

- Many times, abuse of older adults by family and friends can arise from stress, caregiver burnout and a lack of knowledge about how to provide care. ***This booklet has chapters which cover all of these topics.***
- Family caregivers also often need assistance and support from others. Those in extended families, churches, community groups and neighborhoods can reach out and offer support and assistance. This is particularly true in situations with memory impairment.
- Those who become concerned about an older adult's well-being can and should report their concerns to one of the resources listed on **p. 79**. For situations of immediate danger or suspected theft, those in law enforcement should be contacted.



Prevention of Victimization by Paid Caregivers

- Older adults can be victimized by paid caregivers in a number of ways. Some examples include: wasting time instead of doing tasks, making personal phone calls, watching television rather than doing a task, stealing money or articles from the home, and borrowing money or articles from the person.
- The older adult may respond in a number of ways. Common responses include: not realizing or acknowledging what is happening, feeling sorry for the worker and continuing to allow the behavior, fearing reprisal if they report the worker.
- Families need to be very vigilant to prevent victimization. Often the methods used are not obvious to the casual observer.
- **Two** very effective **techniques** to prevent victimization include the use of a task check sheet and frequent unannounced visits to the older relative's home. Older adults are much less likely to be taken advantage of if the worker knows there are people watching the situation closely.

Resources

- **Ohio Department of Job and Family Services, Adult Protective Services** helps vulnerable adults aged 60 and older who are in danger of harm, are unable to protect themselves, and may have no one to assist them. Call 855-644-6277 or visit www.jfs.ohio.gov. Search using the term "Adult Protective Services." You can also make an online referral at this website or reach out to your county Adult Protective Services Department.
- **The Ohio Attorney General's Elder Justice Initiative** helps protect older adults and enhances elder abuse victims' access to vital criminal justice services. Call 800-282-0515 or visit www.OhioAttorneyGeneral.gov.
- **Pro Seniors** provides a free Legal Hotline for information, advice and referrals for Ohioans aged 60 and older. Call 800-488-6070 or visit www.proseniors.org.
- **Ohio Department of Aging, Long-Term Care Ombudsman** provides advocacy for Ohioans receiving home care, assisted living and nursing home care. Call 800-282-1206 or visit www.aging.ohio.gov.

Click here to return to the table of contents.

CHAPTER 4

The Nuts and Bolts of Care

Section 4.1

Adapting a Home
for Caregiving (p.82)

Section 4.2

Working with Wheelchairs (p.85)

Section 4.3

Assisting Someone to Stand,
Sit Or Transfer (p.88)

Section 4.4

Pressure Ulcers and their Care (p.93)

Section 4.5

Common Equipment and their Uses (p.95)

Section 4.6

Safety and Disaster Considerations (p.100)

Section 4.7

Managing Medications (p.111)

CHAPTER 4



Chapter 4

4.1 *The Nuts and Bolts of Care: Adapting a Home for Caregiving*

Getting Professional Input

- Look for professional input on ideas to modify your home. Some professionals who can provide you information include:
 - Occupational Therapists, Physical Therapists Recreational Therapists, Rehabilitative Design Consultants
- Medicare and insurance will sometimes pay for professional advice. However, first you will need to ask your physician for a written referral.

Making the Home Safer/Modifying the Home

- A family should pay particular attention to safety of the living area (especially if it is a house or apartment, built many years ago).
- Modifications can vary from simple and very inexpensive to very extensive and expensive. Sometimes all that will be required is a change in traffic patterns.
- Reducing clutter is perhaps one of the most helpful modifications in most homes.
- Families can be very creative in adapting the living space to meet their relative's needs.
- Sometimes families are reluctant to make changes to the living environment because they feel it will change the resale value of the home.
- However, most changes today can be made in a way that they can either be easily removed or can actually increase the value of the home.
- Many changes might be tax deductible (see **p.72** for more information).
- Universal Design is a term which refers to the process of designing homes and products that will be usable by everyone and not have to be modified to accommodate a disability. The principles of universal design are becoming more popular in the building and design fields. If you are building or renovating a space, you may want to research some information about universal design features.
- Helpful websites include:
 - www.disabilityresources.org
 - www.homemods.org
 - www.aarp.org

Safety in the Home: Questions to Consider

Lighting

- Is the lighting adequate but not glare-producing?
- Are the light switches easy to reach and to turn on?
- Can lights be turned on before entering rooms?
- Are night-lights used in appropriate places?



Hazards

- Are there throw rugs, highly polished floors, or other hazardous floor coverings? If so, where?
- Can they be removed or made less hazardous?
- Do area rugs have non-slip backing and are the edges tacked to the floor?
- Are cords, clutter, or other obstacles in the pathways? If yes, can they be cleared?
- Are doorways wide enough to accommodate assistive devices?
- Do door thresholds create hazardous conditions?
- How does the person obtain objects from hard-to-reach places?
(Chairs can be hazards.)

Furniture

- Are chairs the right height and depth for the individual?
- Do chairs have arm rests?
- Are tables sturdy and won't tip if leaned on?
- Is small furniture placed away from pathways?

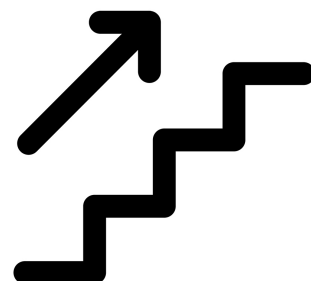

Stairways

- Are there light switches at the top and bottom of the stairs?
- Are there securely fastened handrails on both sides of stairs?
- Are all the steps even?
- Should colored tape be used to mark the edges of the steps, particularly the top and bottom steps?

Notes:

Safety in the Home: Questions to Consider

Bathroom

- Are grab bars placed appropriately for the tub and toilet?
- Does the tub have skid proof straps or a rubber mat in the bottom?
- Is there a tub or shower seat available?
- Can the shower head be replaced by a hand-held showerhead?
- Is the height of the toilet appropriate?



Bedroom

- Is the mattress firm enough at the edges to provide enough support for sitting?
- If the bed has wheels, are they locked securely?
- Would side rails be a help or a hazard?
- When side rails are down, are they completely out of the way?
- Is the pathway between bedroom and bathroom clear of objects and well lighted at night?
- Would a bedside commode be useful, especially at night?

Kitchen

- Are storage areas used to the best advantage, e.g., frequently used objects are in accessible places?
- Are appliance cords in good condition and out of the way?
- Are non-slip mats used in front of the sink & refrigerator?
- Are the markings on stoves and other appliances clearly visible?

Emergency

- Is an emergency response system available (911)?
- Does the person know how and when to use it?
- Would a private emergency call service be helpful?
- Is the person's vital information listed in a place where it would be accessible in an emergency?

Temperature

- Is the temperature comfortable for the person?
- Can the person read the marking on the thermostat and adjust it?
- Is water temperature less than 110 Fahrenheit?
- During hot weather, is there adequate ventilation?
- During cold weather, is the furnace working properly?
- Is there a back-up plan if the heat does not work properly?

Click here to return to the table of contents.

Chapter 4

4.2 The Nuts and Bolts of Care: Working With Wheelchairs

Parts of a Wheelchair

Standard wheelchairs usually:

- Are propelled manually.
- Have two large rear wheels.
- Have two small front wheels.
- Have footrests which might fold and detach.
- Have armrests which might detach.
- Can be folded.

Basic parts of standard wheelchairs:

1. Handgrips
2. Soft seat and back (usually vinyl)
3. Armrests
4. Footrests
5. Front wheels
6. Rear wheels
7. Tilt bar
8. Brakes or locks
9. Brake lever

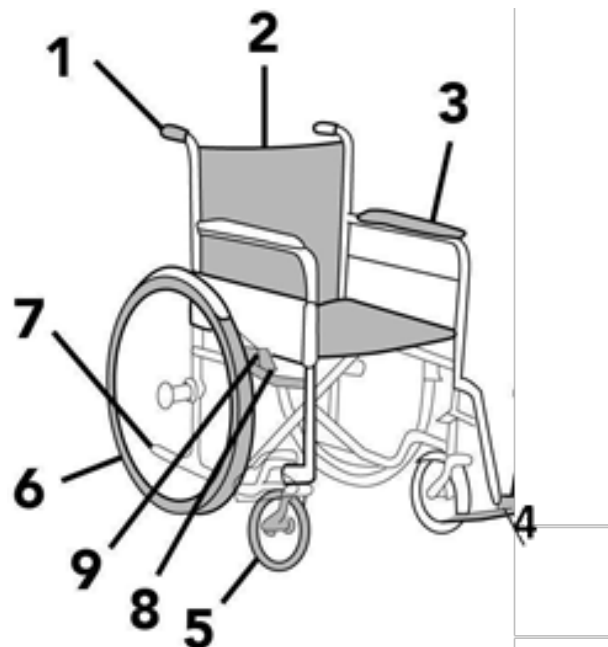

Note:

Standard wheelchairs may have modifications that make them more comfortable or safer for the person. However, these modifications may make working with the wheelchairs more difficult or complicated. When in doubt, get professional advice. Most insurance will pay for a wheelchair with a doctor's prescription. Try to get a customized chair at one of the providers who have a wheelchair fitting clinic to make sure it is the correct chair for the person.

Power wheelchairs are basically the same design as manual chairs, except they are much **heavier** and generally **do not fold**.

Wheelchair DOs and DON'Ts

DO:

- **Think** of the wheelchair as an extension of the person. Wheelchairs replace body movements.
- **Ask** permission before you assist. If your help is declined, stand by ready to assist.
- **Treat** the wheelchair **carefully**.
- **Prepare** the person for movement with a verbal cue.
- Always **assume** wheelchair brakes can **fail**. Place the wheelchair on level ground if possible.
- **Check handgrips** before attempting to move; they should not slip.
- **Wear** shoes that are supportive, close toed, and non-skid.

DON'T:

- **Lift** a wheelchair by the **wheels**. The chair can spin around, spilling the person.
- **Lift** a wheelchair by the **armrests** or **footrests**. Both of these can detach.
- Take a wheelchair up or down **multiple** steps without assistance. This is a dangerous procedure even with assistance.
- **Cross** a wet, spongy or uneven surface with a wheelchair. These surfaces can cause a person to tip forward from the chair. Even a sidewalk crack can be unsafe. Turn the wheelchair backward and allow back wheels to go first if you have no other option.
- **Touch** a person in a wheelchair from the back or side without approaching from the front first.
- **Wear** open toed sandals, flip flops or shoes with a heel when pushing someone in a wheelchair.

Folding and Unfolding a Wheelchair

To Fold:

- Face the side of the chair.
- Push the center of the back outward.
- Grasp the front and back of the seat.
- Pull the seat up and squeeze the handgrips to bring the sides together.

To Unfold:

- Push down with both hands at the same time on the front of each seat rail until the chair unfolds. Do not pull on armrests, footrests, or wheels.

Taking a Wheelchair Up and Down

UP a curb or step

- Face the wheelchair toward the step or curb.
- Grasp the push handles firmly.
- Tip the wheelchair back, using one foot on the tilt bar for leverage.
- When the front wheels clear the step or curb, move the chair forward until the back wheels are against the curb or step.
- Push your body forward against the back of the wheelchair, as you lift straight up on the push handles, to roll the back wheels up and over the step or curb.

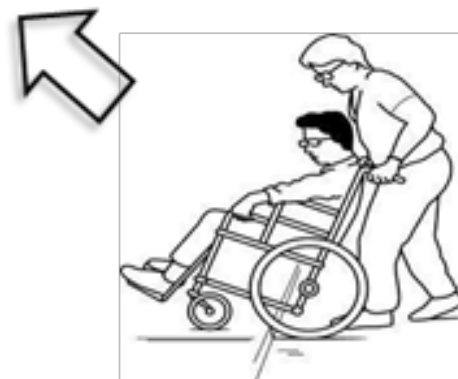

DOWN a curb or step

- Face the wheelchair away from the step or curb.
- Stand on the ground below the curb or step.
- Grasp the push handles firmly.
- Pull the chair slowly toward you.
- Be prepared for an increase in the weight and for the force of the chair against you as it rolls down the curb or step.
- Lower the chair slowly and gently until the back wheels are on the ground.
- Tilt the wheelchair back, using one foot on the tilt bar for leverage.
- Pull backward until the front wheels and footrests clear the step or curb. Don't move straight back or you might hit the person's feet. Instead, turn the wheelchair to the left or the right to lower the front wheels.
- Lower the front of the chair slowly using the tilt bar.

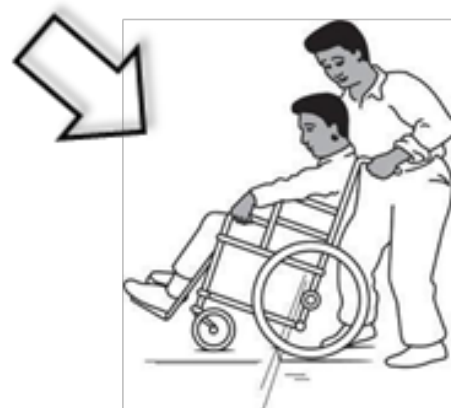

[Click here to return to the table of contents.](#)

Chapter 4

4.3 *The Nuts and Bolts of Care: Assisting Someone to Stand, Sit, or Transfer*

When You Assist, Always...

- Remember you want to avoid injuring the person and yourself.
- If you will be assisting someone often, you should receive professional instructions. Ask a physical therapist or other professional to provide guidance for you in assisting your relative.
- The guidelines are very simple and may already be familiar to you. These are:
 - Ask permission first and listen for a response.
 - Prepare the area ahead of time.
 - Use the person's existing skills.
 - Use your voice to help guide him/her (Count 1,2,3 with the person).
 - Wear low, close toed, non-skid shoes.



Remember the Principles of Body Mechanics:

- Turn your entire body; do not twist at the waist.
- Bend down at your knees/lift with your legs, not your back.
- Bring objects as close to your body during the lift as possible.
- Keep one foot in front of the other, shoulder length apart.
- Lift with your mind, then with your body (In other words, plan your moves.)
- When in doubt, get assistance.

TWO-HANDED Assistance to Stand or Sit

- Stand sideways in front of the person with your feet together. You can be faced either to the left or the right.
- Place your feet in front of the person's feet to prevent them from sliding. The person's feet should be firmly on the floor about 8 inches apart. You may need to assist the person to move their feet into position. Both you and the person should be wearing flat, close toed shoes to prevent injury.
- Bend your arm closest to the person up 90 degrees at the elbow and parallel to the ground. Grasp the wrist of that arm with your free hand forming a kind of human grab bar.
- Allow the person to grasp your forearm with both of his/her hands.
- Slightly bend your knees.
- Count to 3 with the person and on the count of 3, move your outside leg sideways about a foot and shift the weight of your body toward that leg.
- This movement will allow your person some momentum to rise up into a standing position.
- Wait until the person is securely standing before moving your feet.

Two-handed Assist to Stand



One-handed Assist to Stand



ONE-HANDED Assistance to Stand or Sit

- Stand sideways in front of the person with your feet together facing the direction of the person's good arm.
- Place your feet in front of the person's feet to prevent them from sliding. You may need to assist the passenger to move their feet into position. The person's feet should be firmly on the floor about 8 inches apart.
- Form a cup with your hand closest to the person and "catch" the person's elbow gently into it and allow him/her to grasp your arm above the elbow. Then place your other hand on the person's wrist to secure your hold.
- Slightly bend your knees.
- Count to 3 with the person and on the count of 3, move your outside leg sideways about a foot and shift the weight of your body toward that leg. This movement will allow your person some momentum to rise up into a standing position.
- Wait until the person is securely standing before moving your feet.

Assisting Someone to TRANSFER from Seat to Seat- Standing Pivot Transfer

When to Use this Technique:

- When the person can bear weight on his/her legs and pivot.
- When the person can hold on to handles, or other surfaces.

Do NOT Use this technique:

- When the person cannot bear weight on his/her legs.
- When the person is much heavier or taller than you are.
- If you have a disability which makes lifting or turning a health hazard.

Alternatives to Standing Pivot Transfer

- Two person transfer-one person on each side of the person needing assistance. Each person faces the passenger and puts their arm under his/her arm. They then grasp the gait belt with their other hand. This technique also uses a gait belt around the passenger's waist for stability.
- Use a mechanical or standing lift to transfer the person.

Directions: (see illustrations p.91)

- Place the wheelchair as close to the seat or bed as possible, at a 90-degree angle.
- Lock wheelchair brakes and remove the footrests & face the person.
- Place one foot between the legs of the person & one foot in front of the chair.
- Secure the gait belt around the person's waist. It should fit snugly without being too tight.
- Clasp your hands firmly to the gait belt behind the person's back. The person's arms should **not** be around your shoulders. They should be holding on to one of the seat arms or pushing up from the seat.
- Count to three with the person.
- On the count of 3, using your legs, assist the person to come to a full standing position.
- Slowly pivot the person and turn toward the wheelchair, until the person's legs are against the front of the other seat.
- Bending your knees, lower person gently to the seat and remove the gait belt.



Standing Pivot Transfer Illustrations

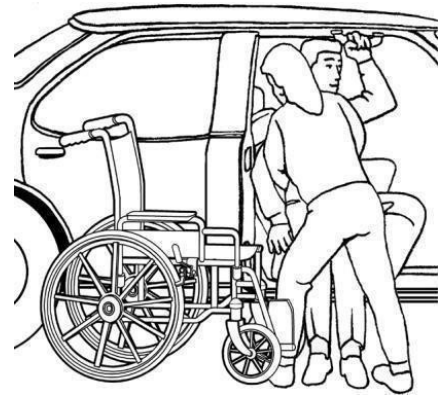
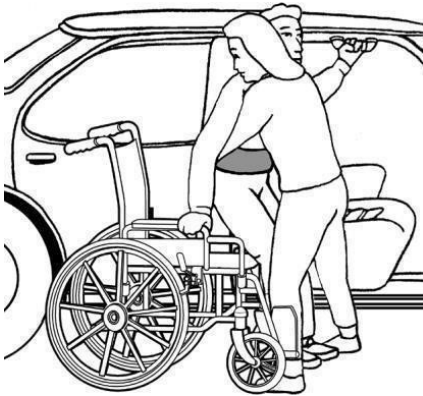

Standing Pivot Transfer in and out of an Automobile Illustrations

Positive Physical Approach™

When a person has any form of disability or sensory loss, it is helpful to approach and assist a person using the following techniques.

ALWAYS:

- Approach from the Front–NOT from the side or from behind a person!
- Go slow. Get low–match person’s eye level.
- Pause at the edge of personal space (about 1½ arms’ length)
- Offer your handshake with a greeting and a smile.
- Use the person’s name (which name do they prefer?)
- Introduce yourself. If you wear a nametag up near your neck point to it.
- Wait for a response.
- Wait for the person to allow you to move in closer.
- Get to the side—the person’s dominant side.
- Use Hand UNDER Hand Assistance™ to escort or assist the person.

Hand UNDER Hand Assistance™

- Offer your hand to the person's dominant hand.
- Slide your hand around so that the thumbs are encircling and the person's hand is on TOP of your hand. Your hand is underneath theirs (supporting theirs).
- Move to the person's dominant side.

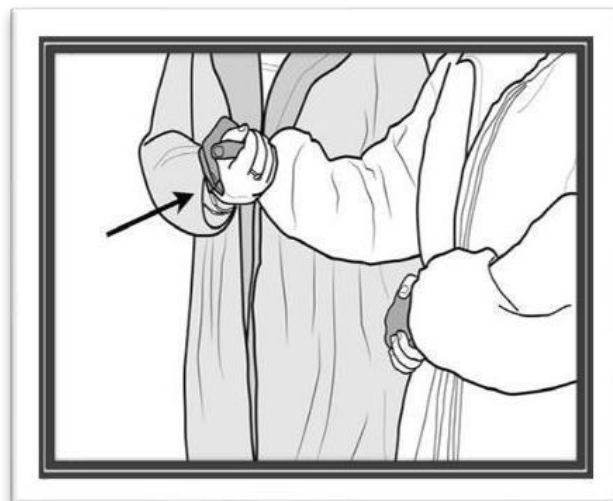

Uses of this Stance

- Use this stance to exert light palm pressure which can be calming.
- Use this stance to gauge a person's response to touch.
- Use this stance to allow a person to have some privacy in personal care.
- Use this stance to establish safe physical boundaries.
- Use this stance to guide the person's hand and arm movement.

Your Other Hand

- Can place on the person's shoulder if they will tolerate a little light pressure.
- Can hold on to the person's opposite hand to steady while walking (see illustration above).
- Can use to assist in personal care (i.e., holding the shower wand).

Click here to return to the table of contents.

**Positive Physical Approach™ and Hand Under Hand Assistance™ are techniques developed by Teepa Snow OTR/L and used with permission by Positive Approach to Change (PAC) 2017. For more information and other training materials go to www.teepasnow.com.*

Chapter 4

4.4 *The Nuts and Bolts of Care: Pressure Ulcers and their Care*

People who stay in bed or in wheelchairs for long periods of time are at great risk of developing pressure ulcers also called pressure sores or bed sores. These are painful and difficult to heal once they are formed. It is better to prevent them from forming.

Pressure ulcers can be caused when skin is:

- Rubbed or dragged against a surface.
- Irritated by urine or feces.
- Left in a position for an extended period of time (two hours or more) with limited movement.

Preventing Pressure Ulcers

- A bed bound person needs to change position at least every two hours and a wheelchair-bound person needs to shift about every 15 minutes.
- When washing an area of the person's body, PAT—never rub— with a warm soapy washcloth and PAT the area dry.
- GENTLY massage areas which have been under pressure with lotion to increase circulation and replace moisture.
- Gently clean urine or feces immediately with warm water and soap.
- If incontinence is an issue, avoid using disposable pads that hold the moisture on the skin. A waterproof cloth pad that can be laundered and reused is a good alternative.



What to Look for:

The first signs of a pressure ulcer include:

- Redness on unbroken skin lasting 15-30 minutes or more. On people with darker skin, the ulcer may appear to look blue or purple. Compare the spot to the same area on the other side of the person's body.
- A small open area like a cut.
- An abrasion, scrape, blister, or shallow indentation.
- Texture changes—the skin feels mushy instead of firm to the touch.
- A gray or black scab. Beneath the scab may be a pressure ulcer. Do not remove the scab— this could cause infection.

If You Think a Pressure Ulcer is Developing:

- Remove pressure from the area immediately.
- Recheck the skin in 15 minutes and if the discoloration is gone, no other action is needed.
- If the redness is not gone or an open area develops, call your doctor immediately.
- Do not massage the area or the skin around it if you suspect a pressure sore is developing.
- Do not use a heat lamp, hair dryer, or heating pad that could dry the skin around the area.



[Click here to return to the table of contents.](#)

Chapter 4

4.5 *The Nuts and Bolts of Care: Common Equipment and their Uses*

Listed below are 10 products which can help caregivers provide assistance more safely and effectively at home. This is by no means a complete list and hundreds of products are available either from durable equipment suppliers or through home health catalogs. For information on what may be useful for your situation consult a **physical therapist or occupational therapist**.

Gait or Transfer Belt

Description: A gait or transfer belt is worn around the older person's waist. It provides a **secure point** for the caregiver to hold while assisting the person in standing, walking or transferring. It is available in a variety of styles. **We strongly recommend that you use one.**

Cost: \$10-\$25. Medicare usually does not cover this product

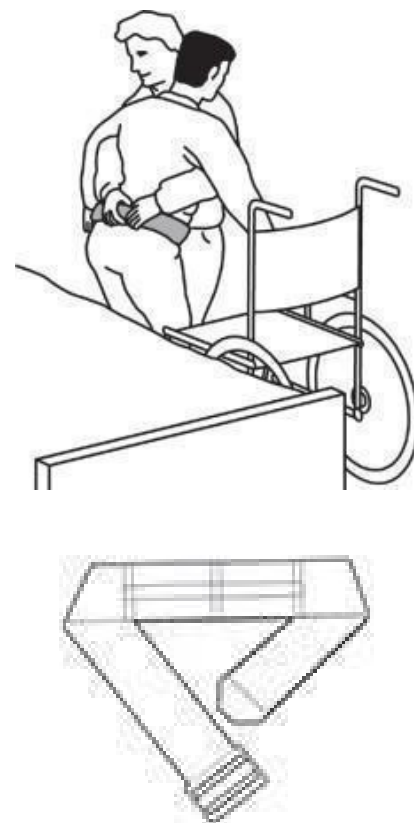

Lifting Belt for Helpers

Description: A lifting belt can be worn by a person when he/she assists someone to transfer. These belts were originally marketed as back protection and support. We know now through research that the belts do not offer protection in and of themselves, but that people who wear them have fewer back injuries. Researchers suspect this occurs because the belt causes the helper to be more aware of his/her back when he/she wears it.

Cost: \$30-\$45. Medicare does not cover this product.



Sliding Board

Description: A sliding board is approximately 2 feet long and 8-10 inches wide, usually with a handle on one side and one edge slightly sloped. It can be used between surfaces of similar heights as a “**bridge**” to assist someone to slide from one surface to the other. The person should have some strength in their arms and be able to move him/herself over.

Examples for its use are a wheelchair to a raised toilet, a wheelchair to a chair, a bed to a wheelchair, or a wheelchair to a car seat.

Cost: \$10-\$25. Medicare does not cover this product.



Gliding Board

Description: A gliding board is a curved version of a sliding board with a round disk in the middle, which moves the person across its surface. It can make transferring much safer for the person and for the person assisting in the transfer.

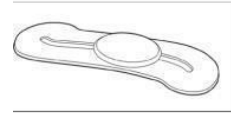

Cost: \$50-\$200 depending on the size. Medicare does not cover in most cases.

Draw Sheet

Description: A draw sheet is simply a **folded sheet placed under a person** who has difficulty turning over in bed. It is folded so that there is approximately 20 inches on each side of the person in bed. One or two caregivers can grasp this extra cloth to **carefully reposition** the person in the bed. A draw sheet can help avoid putting excessive pressure on the bed bound person's skin or bones. It can also ease the strain on the caregiver's back.



Lift Chair

Description: Many manufacturers make assistance devices for chairs. Chairs with the lift mechanism permanently built into them have the appearance of a regular chair but can mechanically lift to assist the person to stand and sit.

Cost: The lift seats (portable models) are \$40-\$200 and the lift chairs (permanent models) are \$600-\$1,500. Medicare will cover the motors of the lift chairs but not the lift seats.



Mechanical/Hoyer Lift or Hoist

Description: A mechanical lift should be used when the person cannot assist at all in a transfer, when he/she outweighs the caregiver, or when the caregiver cannot assist in a transfer for a health reason. Mechanical lifts are used quite often in health care settings. They are large and rather costly.

However, having one to assist in transfers may be the only way a person can remain at home. A caregiver should receive professional instruction when renting or purchasing a lift.

Cost: \$800-\$2,000. Medicare can cover this product with a doctor's order.

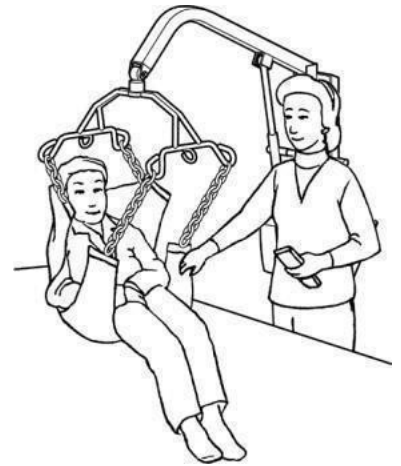

Standing Lift

Description: A standing lift is **smaller** and **easier** to use than a full-size mechanical lift. It assists the person to stand and transfer from a wheelchair to a bed or to a raised toilet seat. It should not be used with someone who cannot assist at all.

Standing lifts are relatively new and not available in all places. Caregivers should receive **professional instruction** if they purchase or rent one.

Cost: \$1,000-\$4,000. Medicare can cover this product with a doctor's order.

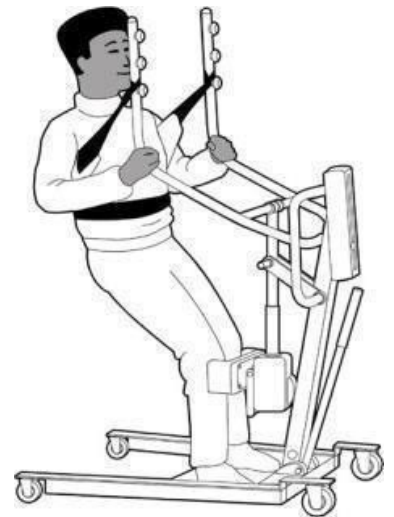

Walker (Can also be called a Rollator)

Description: A device to assist with stability in walking and maneuvering. Can be used in or outside the home. Walkers come in a variety of sizes and colors. Most are square framed though some are shaped like a triangle. Some have wheels and handbrakes, and seats. Others have baskets for carrying items from one location to another. Families should look at a wide variety of walkers before deciding upon one that best fits the person's needs.



Cost: \$100-\$600. Medicare can cover some models with a doctor's order. Some insurances will also cover with a physical therapy assessment.

Shower Chair/Transfer Bench

Description: These products are designed to either assist a person to transfer into a bathtub or remain seated while taking a shower. They are available in a variety of models, heights and lengths. They fit in most standard tubs or showers and are constructed of sturdy material which is easy to clean and sanitize.

Cost: \$50-\$200. Medicare does not cover this product.



[Click here to return to the table of contents.](#)

Chapter 4

4.6 *The Nuts and Bolts of Care: Safety and Disaster Considerations*

Steps to Emergency Preparedness Create a Personal Support Network

- Have a written list of at least 3 people who can help you if needed.
- List ICE (In Case of Emergency) in your cell phone contacts.
- Have a communication plan with those you know both in and out of town.
- Keep emergency numbers posted. Include utility contact numbers.

Create a 'Grab & Go' box to include:

- Your priority list of items to take (home items, adaptive equipment)
- Small amount of cash
- Emergency contact names and numbers including doctor, clergy, etc.
- Copies of License, State ID, Passport or a recent photo of you (name on back)
- Copies of birth certificate, SS card, benefits eligibility letter (SSI/SSDI)
- Financial power of attorney, health care power of attorney and living will documents
- Written instructions for your personal care/transport/medical equipment
- Copies of prescriptions for medicines and glasses
- Copies of all insurances; medical, home, car
- Copies of other important family documents along with a family photo
- List of bank and credit card account numbers
- Household goods inventory and computer disc backup
- All items should be in a plastic zip-lock bag to protect from moisture.

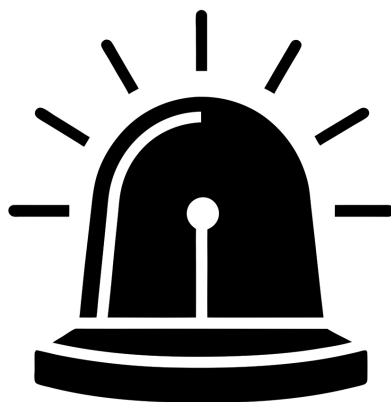

Additional supplies to consider:

- Matches in a waterproof container
- Kitchen accessories and cooking utensils
- Extra clothing and pillows/blankets
- Empty large coffee can/chip tin for emergency bathroom needs
- Small basic tool kit: hammer, screwdriver, spade
- Duct tape, plastic garbage and zip-lock bags
- Pet supplies: leash, food, water, carrier
- Backup batteries for adaptive equipment: scooters, breathing machine, etc.
- Alternative power, heating and cooking sources
- A local map

Sheltering at Home

- Keep the contact numbers for your utility companies nearby.
- Know how to turn off your utilities and water if needed.
- Get your disaster kit and check status of supplies.
- Keep your 'Grab & Go' box nearby.
- Turn on NOAA Weather Radio and follow recommended instructions.
- Turn off or unplug unnecessary appliances.
- Check in with your personal support network; otherwise only phone for emergencies.
- If your electricity goes off, avoid opening your refrigerator/freezer as much as possible.



If You Must Evacuate

Assume that you'll have 3-5 minutes to leave

- Collect your basic disaster kit and 'Grab & Go' box (includes cash, coins etc.).
- Contact your personal support network and tell them where you are going.
- Take food and water supplies with you.
- Take your medications, medical supplies, and adaptive equipment.
- Take a cell phone and batteries.
- Make sure your gas tank is full if driving yourself to shelter.
- If permitted take your pet and necessary supplies.
- If you have a laptop computer take it with you along with your disc backup.
- Turn off all lights and unplug all appliances including computer.
- If you have a disability, take your written instructions for your care needs and any adaptive equipment usage.

If You Are Traveling by Car:

- Always keep your tank between half and full.
- Items to keep in your trunk:
 - Flares, flashlight and batteries, tire repair kit, white flag, and jumper cables
 - Basic first aid kit, some food supplies, and some water
 - Blankets/jacket/hat/gloves/scarf
 - Small shovel, basic tool kit, and kitty litter in case you get stuck in mud/snow/ice
 - Mini version of the basic emergency kit specifically for car
 - Seasonal supplies: sunscreen, hat, umbrella for shade, etc.

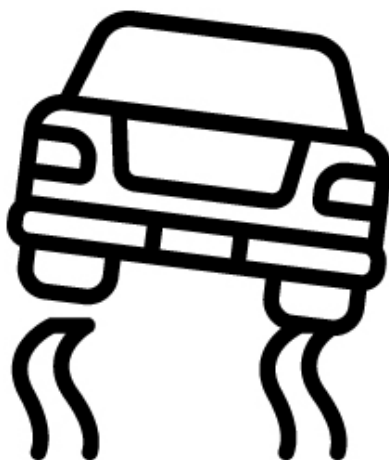

Specific Considerations for People with Disabilities:

- Have written instructions for care needs to include if you need help with: Walking, transferring, standing, communicating, personal care needs or adaptive equipment.
- Use your personal support network.
- Have your emergency contacts list located in a conspicuous place in your home.
- Have identification or ID bracelet ON persons who may tend to become confused.
- Keep a seven-day supply of medications on hand.
- Have backup batteries for medical equipment or scooters.
- Identify your evacuation route. Remove objects that block your path.
- Consult the Red Cross website for Disaster Preparedness and look up 'Persons with Disabilities' section www.redcross.org.

Specific Considerations for Pets:

- Have ID on your pet and a current rabies tag.
- Have medical records of immunizations and any medicine your pet needs.
- Take food, water and sanitation needs.
- Take a leash and carrier: your pet may be hard to manage in the stress of an emergency.
- Take photos of your pet in case it gets lost.
- Keep a bag packed for your pet. Include a comfort toy or item.
- Make prearrangements for where to leave your pet if you have to evacuate since shelters may not take pets unless they are service animals.
- Make note of hotels outside of your area that take animals or a facility that can shelter pets in an emergency.



If You Are Traveling by Air or Staying in a Hotel:

- Travel with a mini basic disaster supply kit.
- Take copies of all prescriptions (medications, eyeglasses).
- Energy bars and nuts are a great food source for travel.
- Give your itinerary to a trusted friend and check in with your personal support network.
- Count how many seats away you are from the exit in an airplane.
- Count how many doors away from the stairwell you are from your hotel room.
- Read the fire evacuation instructions on the back of the hotel room door.

Specific Emergency Plans Tornado

- Know the safest place in your home. Usually this place is on first floor or basement or an interior wall away from windows.
- Take a radio, flashlight, cell phone, and your disaster kit with you to that location.

Snow

- Keep at least a 3-day supply of food and water (one gallon per person per day) on hand at all times.
- Use food in your refrigerator first and then food from your freezer. Open these doors as little as possible.
- Keep battery-operated lights or flashlights available with backup batteries. Also have a supply of candles and matches.
- Keep your first aid kit nearby.
- Dress in layers to stay warm.
- Always keep a supply of needed medications.
- Consider alternative cooking sources if your electricity/gas is off: camp stoves with propane (be sure to follow safety guidelines) or fireplace.
- Use caution and follow all safety guidelines when using alternative heat sources.
- Kerosene heaters are not recommended.
- Have a plan for an alternative place to stay within close driving distance.

Fire

- Keep a smoke alarm on each floor. Check or change batteries with the time changes.
- Have a fire exit plan and practice home fire drills.
- Know what to do if you have special needs or a disability.
- Keep a fire extinguisher (ABC type) in/near the kitchen and know how to use it.
- If there's a fire in a part of the house:
 - Before leaving your room: feel the door with the back of your hand at the top of the door, feel the doorknob. If HOT, Do NOT open!
 - If you open a door and smoke pours in, close the door and block cracks with wet towels if possible.
 - When leaving home, if there is smoke, drop to the floor and crawl to safety.
 - Once you leave the house do NOT go back in. Tell the firemen if you suspect someone is still inside.
 - Have a designated place outside to meet so you know everyone is out.



Emergency Contact Information

Emergency Information About Me Forms

(found on pp. 109-110 of this manual—can be torn out.)

This is a means to communicate vital information between individuals, their caregivers, and emergency personnel in case of medical emergency. The form should be carefully completed. Please place on the front of your REFRIGERATOR and attach any pertinent legal documents (i.e., Living Will, Durable Power of Attorney for Healthcare, DNR Orders. Download these forms at www.proseniors.org)

Ohio Next of Kin Registry

Any person can ADD emergency contacts to his/her Driver's License or Ohio State ID at no cost. Emergency services personnel, safety and highway patrol officers can access this information in the event of an accident or incident. To access paper or web forms go to www.bmv.ohio.gov.

Project Lifesaver

Project Lifesaver provides timely response to save lives and reduce potential injury for adults and children who wander due to Alzheimer's, autism, and other related conditions. There are 6 Project Lifesaver programs in Franklin County and 6 in the surrounding counties. Most are located in Sheriff's or Police Departments. Citizens enrolled in Project Lifesaver wear a small personal transmitter around the wrist or ankle that emits an individualized tracking signal. If an enrolled client goes missing, the caregiver notifies their local Project Lifesaver agency, and a trained emergency team responds to the wanderer's area. Check the website for a program in your area. www.projectlifesaver.org

Medic Alert Program

A 24-hour nationwide emergency response service for individuals with Alzheimer's or a related dementia who wander or have a medical emergency. It provides 24-hour assistance. If an individual with Alzheimer's or a related dementia wanders and becomes lost, caregivers can call the 24-hour emergency response line (800-625-3780) to report it. A community support network will be activated, to help reunite the person with the caregiver. Provides an identification bracelet for both the person and family members (if needed). MedicAlert will notify the listed contacts, making sure the person is returned home. There is a small fee involved. The website is www.medicalert.org

Disaster and Emergency Resources

- Lutheran Social Services-Hands on Central Ohio. Call 211 to get information on how to link to services <https://lssnetworkofhope.org/211centralohio/>
- Federal Emergency Management Agency www.fema.gov
- Department of Homeland Security www.ready.gov
- American Red Cross www.redcross.org
- Download "Disaster Preparedness for Seniors by Seniors" www.healthinaging.org
- Download "Emergency Preparedness for Older Adults" www.cdc.gov

Know the phone numbers for your **local**:

City Hall:

Fire:

Police:

Electric Company:

Gas Company:

Red Cross:

Nearest Emergency Shelter:

EMERGENCY INFORMATION ABOUT ME

This is a means to communicate vital information between individuals, their caregivers, and emergency personnel in case of emergency. The form below should be torn out and carefully completed. Please place on the front of your REFRIGERATOR and attach any pertinent legal documents: Living Will, Durable Power of Attorney for Healthcare, DNR Orders.

INFORMATION FOR: _____

Date Form Completed: _____ Date of Birth: _____

Address: _____ Cell Phone: _____

Home Phone#: _____ Medicaid#: _____

Medicare#: _____ Doctor's Phone: _____

Family Doctor: _____

Preferred Hospital: _____

Insurance Company: _____ Policy#: _____

Home Health Care Agency: _____ Phone#: _____

Medical Eqpt. Co.: _____ Phone#: _____

Pharmacy: _____ Phone#: _____

Other Information on Services: _____

IN CASE OF EMERGENCY CALL:

Name: _____

Name: _____

Address: _____

Address: _____

Phone: _____

Phone: _____

EMERGENCY INFORMATION ABOUT ME - Page 2

Do you currently have any of the following?

High Blood Pressure	Yes	No	Heart Disease	Yes	No
Arthritis	Yes	No	Cancer	Yes	No
Diabetes	Yes	No	Stroke	Yes	No
Lung Disease	Yes	No	Glaucoma	Yes	No
Pacemaker	Yes	No	Model#		
Dementia	Yes	No			

Normal Pulse Rate: _____ Normal Blood Pressure: _____

Allergies to Medications: _____

Medication	Dosage	Frequency
1. _____		
2. _____		
3. _____		
4. _____		
5. _____		
6. _____		
7. _____		
8. _____		

Other Medical Related Information:

Click here to return to the table of contents.

Chapter 4

4.7 *The Nuts and Bolts of Care: Managing Medications*

Safe Medication Use: General Guidelines

Many older adults are on multiple medications to treat health conditions. Below are some tips to help use medications safely:

- Get all prescribed medications at the same pharmacy so the pharmacist can maintain an up-to-date list and check for potential problems.
- Read the medication label and inserts carefully for special instructions like avoiding certain foods, other medications and possible side effects.
- Never increase or decrease a medication's dosage without checking first with a person's doctor.
- Give medications with a full glass of water unless the written instructions say to do otherwise.
- Don't crush or chew pills or capsules unless you check with the pharmacist first. Many medications have a coating to protect the throat or stomach lining. A crushed pill could release all the medicine at one time instead of the way it is intended.
- Don't cut pills in half unless they have a line across the middle to show they can be broken and you have checked with the pharmacist. Ask the pharmacist if the pills come in smaller dosages.



Safe Medication Use

- Dispose of all medications that are past the expiration date. Some fire departments and police stations will take possession of these. Check with your local community.
- Store all medications in a cool, dry area. Some bathrooms may be too warm and damp for medications.
- Pay attention to Over the Counter (OTC) medications, vitamins, and herbal products. These include some pain relievers, anti-inflammatory medications, cough syrups, cold medications, antacids, and allergy medications. Though these medications are generally considered safe, they can cause reactions with other medications. It is also possible that an excess amount can be toxic. When in doubt, ask your doctor or pharmacist.
- Use a pill box or container to keep track of which medications need to be taken at different times of the day. Most of these can be pre-loaded a week at a time. Sometimes these have color coded slots for several times during a day. There are also multi alarm boxes, talking medication bottles and other assistive devices that can help.

Questions About a New Medication

Ask Your Doctor or Pharmacist:

- How and when do I take this?
- What is this medicine for?
- Are there any risks or side effects to taking this medicine?
- What should I do if I experience a side effect?
- Will this medicine work safely with the medications I am already taking?
- What food, drink, other medicines or activities should I avoid while using this medicine?
- Will this medicine affect my sleep or activity levels?
- Are there other special instructions?
- What should I do if I miss a dose?
- Is there a generic (not a brand name) of this medicine available?



Keeping a Record

It is a good idea to keep a record of all medications a person is taking. Always bring it with you to doctor appointments. You can keep it in a chart form or a list form.

For Example:

	Medication	Dosage	When to Take it?	Physician	Date	Color & Shape	Special Instructions
1							
2							
3							
4							
5							
6							
7							

Other Information to Put in a Written Medication Record:

- The person's date of birth.
- Pharmacy name(s) and phone number(s).
- Medications previously used and stopped.
- All current doctor names and phone numbers.
- Over the counter medications, vitamins, and any herbal medications taken recently or currently.
- Known allergies.
- Last immunization dates.
- Date the form was last updated.

[Click here to return to the table of contents.](#)

CHAPTER 5

Preventing Burnout

Section 5.1

Strategies for Identifying, Treating
& Preventing Burnout (p.116)

Section 5.2

Common Family Dynamics (p.123)

Section 5.3

Challenging Care Situations (p.131)

Section 5.4

Caregiving Over the Holidays (p.135)

CHAPTER 5



Chapter 5

5.1. Preventing Burnout: Strategies for Identifying, Treating, and Preventing Burnout

Emotions Common in Caring for a Sick Family Member

- Anger
- Grief
- Embarrassment
- Isolation
- Helplessness
- Worry
- Frustration
- Guilt
- Increased Closeness
- Laughter



May feel like you are on a daily roller coaster!

Warning Signs of Stress & Burnout in Caregiving:

- Become irritated over every little thing.
- Lose the ability to laugh often.
- Experience sleep disturbances (too much or not enough).
- Have difficulty thinking about how to get through a day.
- Blame others for the situation.
- Feel overwhelmed.
- Are unable to concentrate.
- Have stomach distress.
- Either gain or lose weight.
- Use alcohol and drugs to cope.
- Neglect your own health.
- Do not participate in activities, which you used to enjoy.
- Feel like you have to do it ALL.

If you experience **one** or more of these symptoms, you should take steps to alleviate the stress. **Caregivers who do NOT do so, risk deterioration in family relations, job performance, mental and physical health.**

What is Clinical Depression?

Clinical Depression IS a treatable illness. It is NOT:

- Just the blues or a bad mood
- A person feeling sorry for him/herself
- Emotional weakness
- Feeling stressed
- Laziness

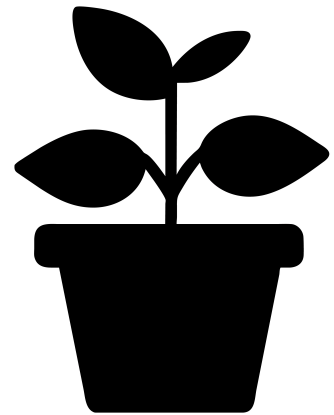

Clinical Depression can be caused by:

- Losses, recent deaths of family or close friends
- Chronic illnesses (stroke, heart disease etc.)
- Medications
- Bio-chemical changes in the body

Symptoms of Clinical Depression:

- Very similar to stress and burnout. However-usually the person has **two or more of them and they last more than two weeks (see list p. 116)**
- They may include thoughts of suicide or a suicide attempt.

Types of Treatment of Clinical Depression: (used in combination usually)

- Counseling or coaching in an individual or group setting-sometimes called talk therapy
- Medications (primarily anti-depressants but also other types of medications)

Where To Go for Help/or More Information:

- Your family physician
- Employee Assistance Program (EAP)-Ask your employer
- National Institute of Mental Health-800-421-4211 or <https://www.nimh.nih.gov/>
- National Mental Health Association-800-433-5959 or www.nmha.org
- National Foundation for Depressive Illness-800-239-1265 or www.depression.org
- Psychology Today at www.psychologytoday.com

Seven Suggestions for Alleviating Stress and Preventing Burnout

1. Set Healthy Boundaries

- In the area of caregiving, establishing healthy boundaries refers to a caregiver setting realistic expectations on his/her **own involvement** or response to a situation.
- Caregivers do not have the ability to set limits on another person's behavior; however, they can control their own response in a way that decreases stressful interactions.
- In establishing healthy boundaries, it can be helpful to identify the stressful situation, decide upon a realistic limit, write it down, try it and be willing to modify it later.
- Boundaries are **not** punishments or retribution but rather a means of remaining physically and emotionally healthy in the caregiver role.



2. Examine Your Expectations of Yourself, the Care Receiver, Family and Friends

How REALISTIC Are They—Given the Circumstances?

Possible Results of Unrealistic Expectations: Anger, Resentment, Frustration, Guilt, and Hard Feelings are all very common consequences of unrealistic expectations in caregiving. If you find yourself experiencing them often, you may need to examine your expectations and modify them in some way to experience less stress.

3. Consider Respite Care & Adult Day Health Services

- **Respite care** is short term assistance by an outside provider (usually in the home) which allows the primary caregiver time free from his/her responsibilities.
- **Adult Day Health Services** provide assistance in a structured environment. Often they provide supervision with medications, social contact, leisure and therapeutic activities, nutritional meals, and transportation to and from the center.
- Accessing and using outside support is not a sign of weakness but a sign of strength.
- Providing opportunities for your loved one to be with others and for you to have a healthy break in routine is an opportunity that benefits everyone.
- These choices are significantly less expensive than care in a facility.

4. Consider Attending a Support Group

Both **disease specific** and **more general caregiver** support groups exist in Central Ohio. Some support groups offer primarily emotional support and practical suggestions while others are more educational.

It can be very helpful to talk to others who are caregiving for advice and encouragement. Please reach out to others.

A complete listing of different types of central Ohio support groups can be found at the Central Ohio Area Agency on Aging website (www.coaaa.org).



5. Suggestions to Take Care of Your Physical and Emotional Health:

- Give yourself a treat -- Get a massage, buy a new outfit, try a new hairstyle, buy yourself some flowers, get an ice cream cone.
- Think of something that would be a total waste of time. Then do it!
- Take a break every day - even if it's only 10 or 20 minutes for quiet time.
- Take a brisk walk. It will help release muscle tension and clear the mind.
- Consider getting a pet. Stroking a pet lowers blood pressure.
- Take up a new hobby or revive an old one.
- Try a bowl of cheerios and milk before bed to promote sleep.
- Reduce your daily caffeine intake--especially in late afternoon.
- Take care of yourself by exercising, eating a well-balanced diet and getting regular medical check-ups.
- Maintain old friendships and develop new ones.
- Plan your days to achieve a sense of balance.

Self care for caregivers is NOT a luxury, it is a NECESSITY!



6. Try Some Relaxation Techniques

There are many different types of relaxation techniques. Try different methods to see what works best for you.

Awareness Breathing (Deep Breathing)

- Erase any stressful thoughts from your mind.
- Relax your arms and shoulders. (You can be lying down, sitting or standing.)
- Now take a deep breath. Let your abdomen and then your chest fill with air.
- Exhale slowly. Repeat the process until your breathing is regular and steady. Let your mind concentrate on each breath.

The Relaxing Sigh

- Start by standing up or sitting up straight.
- Sigh deeply, letting out a sound of deep relief as air rushes out of your lungs.
- Inhale naturally - Just let the air flow in, and repeat several times.
- After each exhale, shake your hands to 'do away' with the tensions you are feeling.

Imagery or Visualization

- Close your eyes and take 3 long breaths. Breathe in through your nose, hold for 2 seconds & slowly exhale.
- Imagine yourself in an ideal place -- a sunny tropical beach, a clear mountaintop, on a lake or in a candle lit cabin. The place can be anywhere that is pleasant to you.
- Use all your senses - smell, touch, hearing, taste - to create your favorite scene.
- Feel and visualize your entire body relaxing in the scenario.

Stretching

- Do slowly and easily without bouncing. Bouncing could cause injury.
- Stand with feet about shoulder length apart. With your arms straight up above your head, gently bend to the side at your waist and stretch, keeping your feet flat on the floor. Now do the other side - using slow gentle movement.
- Gently and slowly roll your head in a counter clockwise position about 3 times, now reverse the direction.
- Gently roll your shoulders forward and then backwards. This will help stretch and relax tight muscles.

7. Sleep!!

Sleep is as important as food and air. Quantity and quality are very important. Most people need between 7.5 to 8.5 hours of uninterrupted sleep. The amount of sleep you need to rest and restore your mind and body might be different than others. Sometimes smartwatches can be set to clock sleep times.

To determine how much sleep you need, observe how much it takes for you to feel rested and alert during the day.

Tips for getting better sleep:

- Keep regular hours & organize your day as much as possible.
- Establish relaxing rituals before bedtime.
- Avoid bright light around the house before bedtime.
- Reserve your bed for sleeping.
- Avoid all stimulants in the evening & remember that Nicotine is a stimulant.
- Avoid alcohol within three to four hours of bedtime. Alcohol may act as a sedative but it disrupts sleep patterns and causes awakenings later during the night.
- Exercise regularly.
- If you nap, try to nap about the same time each day.
- Check your medications. Many medications cause insomnia.
- Create a safe and comfortable sleeping environment.
- If you can't get to sleep for over 30 minutes, get out of bed and do something boring or relaxing in dim light until you are sleepy.

If you cannot get into a restful sleep routine and are not functioning normally, consult your doctor.

For More Information visit the National Center on Sleep Disorders which is within the National Institutes of Health. Website: <https://www.nhlbi.nih.gov/>

Click here to return to the table of contents.



Chapter 5

5.2 Preventing Burnout: Common Family Dynamics

Characteristics of Families

- Every family is unique.
- Cultural diversity exists in families and in our country. It is important to examine our cultural heritage when examining our families.
- Membership in families is not voluntary. Like it or not we are born into them and for most, those bonds are very strong.
- The past is important in families. Past events, conflicts, relationships and bonds can have an influence on current concerns.
- Families are complex to start with but some issues which make them more complex are longevity, number of generations in a family, divorce & remarriage.
- Most people have difficulty stepping back and viewing their own families impartially. This is especially true with the parent-child bond.

Myths & Realities of Families & Caregiving

Myth - In the good old days, families took care of their own members, not like today.

Reality - In the good old days, the average life expectancy was in the 50s. Families had very few older family members. There were few formal services so families for the most part had no choices about assistance.

Myth - Today, families are not involved in providing assistance to older members.

Reality - Survey after survey shows family contact is very frequent for most older and disabled adults. Families are involved in the care for over 90% of both those living at home and those in a care facility.



Common Challenges in Families & Caregiving

SPOUSES PROVIDING CARE

Staying Healthy

- Spousal caregivers often face the huge challenge of staying healthy themselves.
- Often they neglect their own health because they feel that no one else is able to care for their spouse like they do. In fact, they often do provide the best quality of care.
- Sometimes adult children do not see how much care is actually being provided by the well spouse.
- Spouses often need to allow others to help care for the individual in order to take care of their own physical or mental needs.

Guilt Feelings

- Types of guilt which are typical in spouses:
 - Guilt for not doing enough.
 - Guilt for forbidden feelings like anger, resentment, dislike.
 - Survivor guilt (guilt for being healthy while the other person is not).
- Suggestions for coping with guilt feelings:
 - Identify the source of the guilt.
 - Identify what is currently being done.
 - Look at what can realistically be done.
 - Identify when anger and blame are actually guilt.
 - Give permission to oneself to not be perfect.



Intense Range of Emotions

Four emotions are very common in caregiving spouses:

- Ambivalence
- Anger
- Fear
- Worry/Anxiety

Sometimes spouses report they feel like they are on a roller coaster of emotions. This can cause stress and eventual burnout. Talking with other spouses in similar situations can be very helpful. Taking a break from caregiving can also relieve this stress.

ADULT CHILDREN PROVIDING CARE

Relationship Role Changes

- The person in need of assistance often cannot perform tasks that they have for many years. Adult children often face difficult choices as they assume duties formerly completed by their older parents.
- Parents sometimes respond with anger towards the son or daughter who is taking over tasks and responsibilities.
- To minimize the negative effects of role changes it is best to:
 - Change roles as gradually as possible especially when the parent has been doing a certain task for many years.
 - Allow older parents to have as much control as possible. Sometimes adult children must see beyond their own worries about health & safety to allow the ill person to continue in a role which has been meaningful.



Differences in Motivations: Safety vs. Independence

- In many families, there is a very real difference between the adult children's desire for safety & the parents' desire for as much independence as possible.
- These dueling motivations can create anger and resentment on both sides. It can also cause communication to be impaired as parents choose not to let children know about falls, problems and other issues to avoid losing more independence.
- Families often must acknowledge that this different motivation exists and then move towards finding a middle ground in which children allow risk and parents retain as much independence as possible.

Inclusion of Other Generations in Caregiving Responsibilities

- Adult children are often very reluctant to involve their own children in caregiving.
- Some of the reasons could be: "they are so busy, they have their own lives, they have small children". However grandchildren and great-grandchildren can make valuable contributions to a situation:
 - They often bring energy and different kinds of assistance and support (i.e. knowledge of technology, their own small children who can cause joy).
 - They change and often enhance the family dynamics. Involving them and allowing them to contribute often builds stronger bonds within the family.

ISSUES BETWEEN ADULT SIBLINGS

Unresolved Sibling Rivalry

- Sibling rivalry which existed in the childhood and teenage years either gets resolved or goes below the surface in adulthood.
- It often resurfaces when one or both parents need assistance. It complicates caregiving because it brings anger and resentment rooted in the past into the process. Sometimes rivalry can be resolved to some extent by being acknowledged and sometimes it can be ignored successfully.
- Every family will find its own unique solution.

Inheritance Concerns

- Inheritance concerns take different forms in different families. Sometimes it is the money; sometimes it is the house; sometimes it is the things in the house.
- Sometimes it is not the adult children who are concerned but the parents. Sometimes other relatives are involved. These concerns can greatly complicate the caregiving scenario and the choices made.
- Families need to discuss these issues clearly and without anger. Parents should put wishes in writing. Often legal advice can be useful in helping families to draw up appropriate documents and make decisions around inheritance.

Differences in Perception of Needs and Care

- Different relatives perceive needs and care choices differently. All can be perfectly valid choices in the face of disabling illness.
- However, these differences often cause conflict in families especially between siblings. Siblings need to honestly discuss all options and try to understand each other's positions even if they do not agree with them. Sometimes consensus only emerges after these discussions. Sometimes people have to agree to disagree.
- What is most important is to come to the decision which best meets the needs of the ill person(s).



Common Communication Obstacles in Families

1. So Many Things Left Unsaid...

Families often do not discuss the issues around illness and caregiving. Some reasons are:

- We expect people to know without us saying.
- We don't want to argue.
- The truth is difficult to face.
- We don't want to complain.
- We don't want to hurt others.

2. "Dance" Between Guilt and Resentment

- On the one hand, people can be somewhat resentful for the time they spend providing care, for what is happening to their lives, or for what they are giving up to provide care.
- On the other hand, they feel guilty for not doing enough because they love their family member. They keep going back and forth between the two and effective communication does not happen. Instead the cycle continues and can intensify.

3. Relevance of the Past

- Past hurts, relationships, events etc. have an impact on present events in families. Often these past events have not been resolved to the satisfaction of all parties and there are hidden feelings involved.
- Past trauma especially results in buried emotions. Sometimes it is said that people "build a wall around their emotion" after trauma. It can be difficult to communicate if there has been trauma, abuse, secrets, or other unresolved issues in a family's past. People may need to involve professional counseling or mediators to assist in productive communication in these incidences.



Techniques to Overcome Obstacles

1. Identification of Family Strengths

- It can be very helpful to identify family strengths, whatever they may be.
- So often families are stressed and not communicating effectively that all they see is the problems. It can be difficult to recognize the positive that is happening and has happened. Every family has strengths that can be brought to the caregiving process.
- Some examples are: the number of people, skills that members possess, a long history of family closeness, geographic proximity to each other.

2. Use of "I" Statements

- Use "I" messages.
- Start statements with "I feel", "I need", "I am frustrated..." etc. instead of "You."
- This tends to keep both sides from getting defensive.



3. Active Listening

- Active listening can help all parties feel understood even if they do not agree. It can diffuse potentially stressful situations and allow people to communicate honestly.
- The steps of active listening include:
 - Give the speaker your full attention.
 - Encourage the person to speak.
 - Confirm what you heard the person say.
 - Ask open ended questions to clarify.
 - Acknowledge the person's feelings even if you don't agree with his/her statements.
 - Make certain all concerns have been heard before responding.

Hold a Family Meeting

Suggestions concerning family meetings:

- Don't forget to include long-distance family/caregivers if possible.
- Include adult 3rd and 4th generation family members if available. They often bring a productive dynamic to the discussion and a current knowledge of technology.
- Set ground rules for the meeting so that only issues that apply to the current concerns are brought into the discussion (i.e. leaving out old arguments, past issues etc.).
- Appoint a mediator who will move the discussion along. This can be someone from the family, a close friend or it can also be appropriate to hire someone who specializes in these issues. Everyone should have a chance to share and listen to the others.



[Click here to return to the table of contents.](#)

Chapter 5

5.3 Preventing Burnout: Challenging Care Situations

What Behaviors Do YOU Find Difficult? Issues to Consider:

- Sometimes “difficult behavior” is not doing things the way we want them to be done.
- What one person may find difficult, another may not.
- Most of us develop coping techniques earlier in our lives, and these coping techniques go with us as we age. Some people, therefore, have what may be termed “difficult” behavior their entire lives. Chronic illness makes these behaviors more pronounced.
- Perceptions change over time. What may be termed “inspiring” at one point of life may be called “difficult” at another point. Behaviors which may have served people well at another point in life may not serve them as well in a period of chronic illness.
- Chronic illness often involves new and unfamiliar challenges for both caregivers and those receiving care. Even the best relationships are sometimes stressed under such circumstances.

When Difficult Behavior Becomes Abusive Behavior:

There is a fine line between these two but abusive behavior tends to destroy the underlying relationship. The relationship can get to a point that it is beyond repair. Examples of potentially abusive behavior by the person receiving care are:

- Finding fault with errors made in good faith.
- Faking symptoms to get extra attention.
- Waking caregivers thoughtlessly during the night.
- Giving away resources promised to family members.
- Demanding help beyond the caregiver’s capacity.

Caregivers have the right not to be subject to abusive behavior regardless of the situation.

Specific Challenging Behaviors and Suggestions

The Desert of Time:

- Time is opportunity for those without illness and time can become a burden for those with illness who are not able to do what they used to do.
- Family members may give great importance to events that in earlier times would have not raised an eyebrow.
- Family members may spend a huge amount of time preparing and waiting for a ten minute visit. They may get angry at family members for being late or not staying long enough.
- Families often do not fully recognize or understand these issues.

What Is Helpful?

- Suggest/facilitate useful and interesting activities to fill the time more effectively.
- Make an effort to be on time and find ways to make visits truly enjoyable.
- Suggest to friends and other relatives ways that they can help the person fill the time (i.e. bring pictures, mementos, activities of shared interests).

Need for Balance Between Giving and Receiving:

- There is a powerful need for balance in our culture. It is difficult for most people to receive without giving in return. We spend most of our lives maintaining this balance in our families, among our friends, and in our organizations.
- Asking for assistance without a means of repaying it is not something most of us are comfortable doing; however, people with chronic illness find themselves accepting assistance very often with no obvious opportunities to reciprocate.
- There can become this lack of balance in relationships which can be very uncomfortable and lead people to conceal their true needs from family and friends. It can lead them to react with anger or resentment toward people who are there to "help."

What Is Helpful?

- Try as much as possible to build balance into any caregiving arrangement.
- People should be allowed and expected to contribute.
- Reciprocation can take many forms, not just financial. Families often must get very creative to build this balance.

Circle of Influence Decreases:

- For many people with chronic illness, the issues about which they formally **had influence decrease**. For example, people often no longer have jobs or major family responsibilities. They may not be able to keep responsibilities at clubs or at church.
- As a result, they may seem **hyper-concerned** with their own health, with food, with the organization of their belongings in the house etc. They may seem to have become very **self centered**.
- Family members do not always understand these changes though they are **quite common**.

What Is Helpful?

- Let ill people who find themselves in this situation retain as much **decision making and control** over their own lives as possible.
- Family members can also be sources for **new interests**, hobbies, and responsibilities.
- **Two very helpful sources** of activity are pets and music especially for those who have enjoyed these in the past.
- Sometimes people also need **touch, exercise**, and other **sensory stimulation** to remind them that there is a wider world of which they are a part.



Feelings of Regret:

- When faced with chronic or life threatening illness, many people **review their lives**. They look back on decisions they made, the families they came from, the tragedies and the joys.
- Many people want to **discuss these issues** with someone who will listen. Often it is an affirming and enriching experience for both parties. In some cases, however, the person is filled with regrets about “what could have been,” for decisions made long ago, for events that happened long ago.
- This overwhelming **sense of regret** can cause clinical depression, it can cause illness to get worse, and it is certainly painful to watch.

What Is Helpful?

Sometimes family members can be of great assistance by:

- Allowing people to **talk** about these issues without offering platitudes or advice.
- **Listening** without judgment.
- Bringing people together for **reconciliation**.
- **Reconnecting** the person with his or her religious tradition.
- **Professional counseling** can assist some persons to come to a sense of healing.

The “Fear” Factor:

Fear is a natural product of chronic and disabling illnesses. Most people are not comfortable admitting they are afraid. Fear often manifests itself as either **anger or anxiety**.

ANGER

- People who have **anger** as a result of fear can lash out at those who try to assist them. Often they are angry at medical providers as well. They often have **limited safe outlets** for anger so caregivers receive the brunt of their anger.

What Is Helpful for Anger?:

- **Looking** for the source of the anger/fear
- **Counting** to 20 before answering
- **Leaving** the room
- **Developing** defusing statements
- **Using** humor appropriately



ANXIETY

- People can also **worry excessively** as a result of fears. This anxiety can become disabling.

What Is Helpful for Anxiety?

- **Often caregivers can alleviate** some worries by seeking and offering realistic information. Information is **very empowering**, but ill people may not be in a position to gather information about the illness, living options, care options and other issues.
- **Counseling and medication** can assist the person to feel less anxious.

Techniques to Improve the Caregiving Relationship

1. Communicate More Effectively:

- Effective communication can be **difficult** in any situation. It can be even more so in a family involved in caregiving. People do not express feelings for fear of hurting another; people do not want to ask for help for fear of being a burden; people respond in anger or frustration to difficult behavior and so on.
- **Communication** is a two-way street. It involves **both listening carefully** and **expressing yourself clearly**.
- Sometimes we have to unlearn old habits.



Steps to Communicate More Effectively

- Use “I” messages (Start statements with “I feel..”, “I need..”, “I am frustrated...” etc.) instead of “You.” This tends to keep both sides from getting defensive.
- Respect the rights and feelings of other people by what you say or do.
- Be clear and specific.
- Speak directly to the person(s) involved.
- Listen as you want others to listen to you.

2. Examine Your Own Feelings About Caregiving

- Caregivers sometimes need to examine their own feelings as they consider the behaviors of the person for whom they are caring. Feelings of guilt, fear, resentment, and anxiety are very common.
- These may be influencing your responses to difficult behavior. They may even be making the ill person’s behavior worse.
- If you realize that you are feeling resentful or experiencing more anxiety than usual, you may need to get some assistance to relieve your own stress in order to respond in a more effective way.

3. Enlist Support & Assistance:

- **Caregivers need to educate** themselves and seek the information, support and assistance which is right for their situation.

Click here to return to the table of contents.

Chapter 5

5.4 Preventing Burnout: Caregiving Over the Holidays

ASK What is Realistic to Expect of:

- Yourself
- Your Loved One(s)
- Your Family
- Your Holiday Celebrations



Note: LET GO OF THE “SHOULD”!!! It’s OK to make NEW holiday plans!

To Ask Before the Holidays

- What holiday activities do you truly want to preserve?
- What will it take to accomplish that?
- What would you really like to cross off of your list? Delegate???
- Are there interesting, meaningful activities that could replace “higher energy” activities?

To Ask To Help Your Loved One ENJOY the Holidays

- What is your loved one’s endurance?
- What is your loved one’s tolerance for stimulation?
- Do you need to prepare visiting family and friends for changes in your loved one’s appearance, abilities, or behaviors?
- Will travel be stressful for you and/or your loved one?
- What accommodations would be needed for travel?



Ideas for SIMPLIFYING Holiday Traditions

- SCALE DOWN!
- A pot-luck holiday meal is fine.
- Get reservations at a restaurant.
- Use bakeries.
- Draw names for a gift exchange.
- Purchase gift cards.
- Make a donation to a worthy cause in the name of the family/group.
- Get DVDs of favorite holiday movies, concerts or productions to view together.
- Go easy on the decorating.

Advising Others of Your Needs at the Holidays

- Share how life has changed for you and your loved one with your family and share the changes you need to make in your holiday activities.
- Be mindful of your tone, no demands, no accusations. Just the facts.
- Invite suggestions. You may get some creative ideas and offers of help!
- Recognize changes in holiday traditions may be difficult for some family members.
- DO NOT ACCEPT GUILT!

Reach OUT for Respite Care!!

- Respite care provides temporary relief to a caregiver from caregiving responsibilities.

Sources of Respite:

- Family, friends, neighbors – ask early so they can plan to help you during the holidays.
- Paid respite workers – home health aides
- Adult Day Services
- Explore programs that help with the cost of respite care. Eldercare Locator:
<https://eldercare.acl.gov/>

Monitoring Your Stress Level H.A.L.T.S.

A self-check-in strategy

Avoid becoming too:

- Hungry
- Angry
- Lonely
- Tired
- Scared



HUNGRY?

Check In with Yourself

- Energy requires fuel. When did you last eat and drink?
- Energy bars are good in a pinch. But a quiet, unhurried, satisfying meal provides both physical and emotional nurturing. You don't have to do the cooking. Order take out or use a delivery service.
- Or, put it out to family and friends that bringing in a meal to free up some time during the holidays would be a wonderful gift!



Managing Your ANGER

- Anger happens.
- When anger becomes the predominant response to all life situations, it is unhealthy and potentially deadly.
- Anger is typically a “cover” emotion for fear, frustration or hurt. Pay attention to how often you feel angry. Take time to consider the underlying emotions. Identifying the true emotion is the first step in dealing with it. Journaling is a helpful way to process your emotions and is readily available to a caregiver.
- Seek a Healthy Outlet for Anger!!

Combating LONELINESS

- Caregivers are at HIGHER risk for isolation and loneliness than the general population. These feelings tend to surface even more during the holidays.
- ENCOURAGE visits from friends and family – even if they need to be brief. They may be concerned about upsetting your routine. Let them know the best times to visit, what to expect of your loved one, and what to expect within the household.
- The demands of caregiving pose a challenge in maintaining our vital connections to others. Set a goal to catch up with an old friend, classmate or neighbor SOMETIME over the holidays!

Avoid TIREDNESS

- DEEP, UNINTERRUPTED, RESTFUL SLEEP is essential for all of us. It can be particularly difficult for a caregiver to manage this.
- SCHEDULE sleep time, while someone provides you with respite care. Put it on your calendar!
- At holiday time SCHEDULE YOUR RESPITE CARE EARLY!!
- Remember: Caffeine, and nicotine are stimulants and can prevent restful sleep.
- Alcohol has an initial sedative effect—but can cause you to awaken later and have difficulty getting back to sleep.



Dealing with FEAR

- Fear is an emotion that can “drive the bus” for any of us if we let it.
- Uncertainty lies beneath many of our fears.
- Caregivers often live day-to-day with uncertainty on many fronts. Fear can become ingrained.
- Try to pinpoint what is at the base of the fear. Perhaps it isn’t accurate.
- Share your concern with someone you trust to help you gain some perspective.
- Reach out to experts for information to help in problem-solving.

Build in Down Time

Allow yourself time each day to just

“Be”
NO PHONE!
NO COMPUTER! NO TV!
Rest Your Mind!
Breathe!
YOU CAN DO THIS



Through the Holidays and Beyond... KNOW THAT:

- You are Body, Mind, and Spirit
- All of these aspects of your HUMANNESS Require Nurturing for you to remain a Healthy, Whole Person.
- Tune in to yourself. If you struggle with making changes, there is help.
- **Please reach out!!**

Click here to return to the table of contents.

CHAPTER 6

Brain Health & Understanding Dementia

Section 6.1

Maximizing Brain Health (p. 142)

Section 6.2

What Do We Mean by Dementia? (p.147)

Section 6.3

As the Brain Deteriorates:

What Stays and What Goes (p.151)

Section 6.4

Managing Common Behaviors:

Wandering, Bathing, Toileting,
Sleeping, Eating (p.155)

CHAPTER 6



Chapter 6

6.1 Maximizing Brain Health

Our Brain

- Weighs about 3 pounds
- Not large in size but a POWERHOUSE!!!
- HOLDS all memories and emotions
- COORDINATES thoughts, emotions, and movements
- Billions of neurons relay messages around the brain and down to the body every minute of every day we are alive. If these are lost or damaged, the body does **NOT** replace them.



Factors That Can Affect the Brain's Function

- Head injuries caused by falls or accidents
- Illnesses that effect the brain-directly or indirectly
- Sensory Losses (Especially vision, hearing, smell)
- Fatigue
- Medications (legal and illegal)
- Alcohol
- Distractions---i.e. Multi-tasking
- Emotions especially stress and grief

Typical Age Related Brain Changes

- Short term memory challenges--details, names get harder to remember or recall immediately
- We have more information in our memories & it may take longer to retrieve information
- Often we remember what we forget and are troubled by it

THIS IS NOT DEMENTIA!

Dementia: What is It?

- Dementia Equals BRAIN FAILURE—the person’s brain is struggling and perhaps dying—it does not just effect memory.
- Dementia is a SET OF SYMPTOMS NOT a diagnosis.
- Onset is typically SLOW.
- It is **vitaly important** that people get an assessment by a specialist as early as possible if they are experiencing symptoms which are interfering with their everyday life (like getting lost while driving, or having problems with money).

How to MAXIMIZE Your Memory Despite Typical Aging Changes

- **Use** modern memory tools (and some not so modern)—calendars, paper, lists, reminders, post it notes!!!
- **Link** new memories with older established memories—used often on passwords, names, events.
- **Keep** a routine-therby lessening the need to remember common details of life.



8 Habits That Foster a Healthy Brain

1. Movement: The More the Better!!!

- Most adults should have at least 150 minutes a week of moderate aerobic activity (like walking) OR 75 minutes a week of vigorous activity (like jogging, biking, dancing).
- Most adults should also engage in activities that build muscles and strength on a regular basis.
- These improve cardiovascular and lung function. And this serves to feed the neurons in the brain.
- Movement also improves mood and overall wellbeing.



2. Get Enough Sleep AND Rest

- Most adults need 7-9 hours of sleep in a 24 hour period. Brains depend on sleep time to feed neurons and process thoughts.
- Stay off screens before bed and make your sleep space as comfortable as possible.
- Do all you can to minimize sleep disruptions.
- If you have any sleep related problems such as sleep apnea, talk to a health provider.
- ALSO build activities that are restful to you into your day. These are different for each person but they are important. Think carefully about what provides emotional and physical rest for you AND give yourself permission to build those into your day.



3. Exercise Your Brain!

- Talk frequently to another person or persons
- Write a letter or take notes
- Reminisce about past memories
- Learn a new skill, task or language



4. Expose Yourself to Music and Rhythm Everyday!

- What type? Should be music you like from your younger years! There is no bad or good music—but you should stick to what you like and find familiar as music tastes are very individual.
- Dance, tap or sing along!
- Music not only exercises your brain by bringing up memories but it can increase calm feelings, fight stress and give pleasure.
- If you played a musical instrument in the past, start playing again. Learn a new instrument.
- Use modern technology to create song lists and find older songs you still like and enjoy.

5. Do MANY Activities which Access Sensory Memories

Some Ideas:

- Watch familiar movies and tv shows—also familiar game shows.
- Play cards and other strategy games and do puzzles.
- Look at old or familiar pictures-Talk yourself through them and write on the back of them.
- Familiar and pleasant foods: to cook, smell and eat.
- Maximize contact with animals.
- Any skin massage is helpful including hand and foot massage.



6. Protect Your Head!!

- Wear a seatbelt.
- Wear a helmet with a bike, motorcycle, ATV, horse, or skis.
- Prevent falls by removing household clutter, throw rugs and adding lighting to stairs and pathways



7. Watch Your Medicines

Pay close attention to the medicines you take and report changes to your health care providers. Some common medications that can cause the brain to struggle:

- Antihistamines for allergy relief
- Sleep aids (prescriptions & over the counter)
- Antipsychotics
- Muscle relaxants
- Drugs that treat urinary incontinence
- Medications for relief of cramps in the stomach, intestines, and bladder

8. Get Enough Food & Hydration!!!!

- Studies show that many adults do not get enough hydration a day. Most adults need from about 64-80 oz. of non-alcohol beverages every day to stay hydrated. Water and other non-sugar beverages are a great choice.
- Many people now carry their beverage with them in a reusable container and there are many different size, shape and color containers to choose from. Such containers can keep a beverage cold or hot for a longer period.
- Eating healthier foods can also slow cognitive decline. This includes more vegetables and leaner meats/proteins, along with foods that are less processed and lower in fat. There is no "magic" food but a wide variety of different foods seems to be of great benefit to most people.

[Click here to return to the table of contents.](#)

Chapter 6

6.2 Understanding Dementia: What Do We Mean by Dementia?

Typical Age-Related Brain Changes

- Remember that the brain experiences some typical age related changes just like the body's other organs and senses: eyesight, hearing, smell, taste and touch.
- People may notice these changes and be troubled by them. However, they do not significantly alter a person's daily life activities or choices. People may also adapt to these changes like making lists, creating habits or using pill containers.
- If a person or a family is concerned about a brain's function, it is important to have the brain checked just as we would have a check up for any other part of the body if we had concerns. There are many new ways of assessing brain function that have been developed in the last 20 years.



Mild Cognitive Impairment (MCI)

- This can be diagnosed when the brain is starting to **struggle** beyond the simple age related changes and can include: problems with short term memory, language, other brain functions (left temporal region)
- People still generally function independently.
- MAY OR MAY NOT DEVELOP INTO A PROGRESSIVE PROCESS like dementia!
- Estimated to affect about 15% of people between age 60-90.
- SAGE test from OSU is available for screening (www.osu.edu)
- Medications seem to be very effective and should be started if MCI is suspected/ diagnosed.

Dementia: What is It?

- Dementia Equals BRAIN FAILURE—the person’s brain is dying—not just memory decline.
- Dementia is a SET OF SYMPTOMS NOT a diagnosis.
- Onset is typically SLOW.
- Can be caused by factors which are:
 - Reversible (Metabolic Disorders)
 - Treatable (Hydrocephalus)
 - Irreversible (Alzheimer’s Disease)
- Dementia is BOTH
 - Chemical changes in the brain AND Structural changes in the brain.
 - It changes everything over time.
 - It is NOT something a person can control.
 - It is NOT the same for every person.
 - It is NOT a traditional mental illness; people with dementia can have mental illness diagnoses as well.
 - It is real.
 - It is very hard at times.

Some Resources on Dementia

- **Teepa Snow’s Positive Approach to Care Website and Materials** (www.teepasnow.com) *Understanding the Changing Brain*, 2021.
- **Mayo Clinic on Alzheimer’s Disease and other Dementias**, by Jonathan Graff- Radford and Angela Lunde, 2021.
- **Creating Moments of Joy**, by Jolene Brackey, 2017.
- **Website** of Dr. Natali Edmonds called www.careblazers.com which has many YouTube videos and other support for those with dementia and their families.
- **Zinnia TV** which is a subscription service which has many, many interesting videos and materials for those with dementia and their families. www.zinniatv.com
- **Website** of International Alzheimer’s Assn. (www.alz.org)

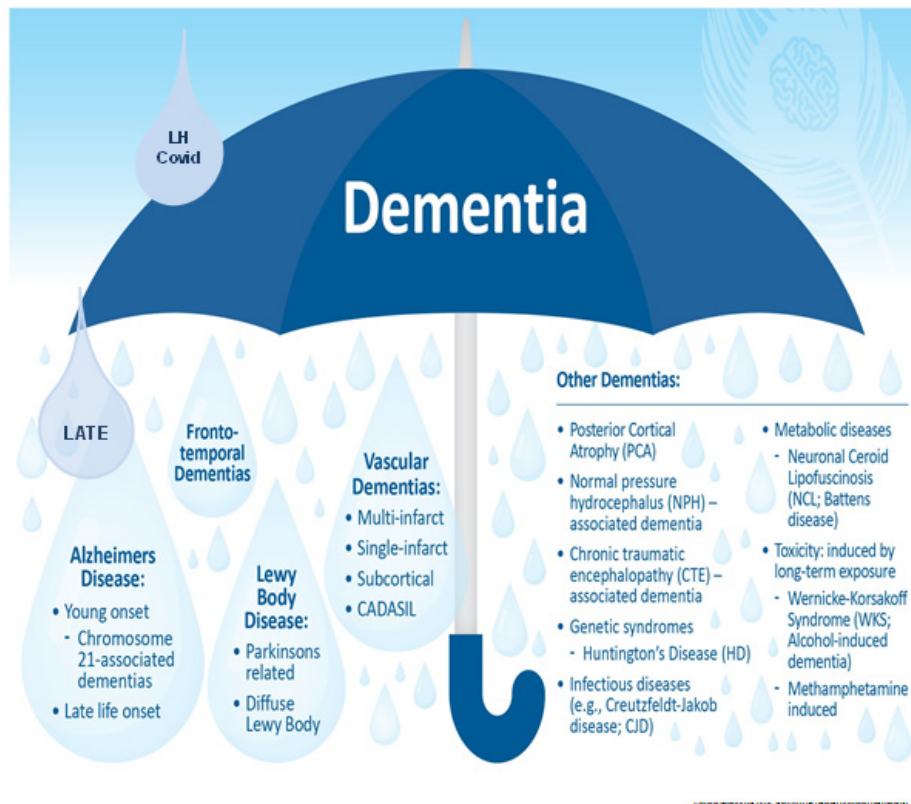

Illustration used with permission*.

Types of Dementia

- **Alzheimer's Disease** - is the most common type of dementia caused by damage to nerves in the brain and their eventual death. It has an expected progression of about 8-12 years and will get worse over time. It is a terminal disease - There is NO known cure at this time.
- **Vascular Dementia (Multi-Infarct)** - is caused by damage to the blood supply to the nerves in the brain. It is spotty and not predictable. The person's condition may not change much for long periods and then experience sudden changes in a short period of time.
- **Lewy Body Dementia** – includes problems with movement, falls & stiffness. Includes visual hallucinations & nightmares as well as fluctuations in performance from day to day.
- **Frontal-Temporal Dementias** – Deterioration starts in the frontal region of the brain. Includes poor impulse control and difficulty with word finding. The person often has rapid changes in feelings and behaviors.

*Used with permission by Postive Approach to Care (PAC) 2025. For more information and other training materials, go to www.teepasnow.com.

Understanding the Three D's

- **Dementia** (progressive, some symptoms are treatable)
- **Delirium** (Short Term, Quick onset, Physical Cause)
- **Depression** (Mood Disorder, Symptoms are Treatable)
- Can and do co-exist at times
- Can and often do mimic each other

Pay Attention To!!

- Sensory Impairments?
- Language Impairment or Language of Origin?
- Significant Existing Psychiatric Diagnoses?
- Recent Transfer of Living Situation or Disruption in Day-to-Day Events?

Suggestions for Interacting More Successfully

- **Don't correct errors**, go with the flow of the conversation.
- Be prepared to hear old stories over and over.
- Use old pictures or props to bring up other old memories.
- Find ways to laugh.
- Do something with the person rather than just talking to them.
- If the person says something distressing or seems worried about something, realize it may not be true, but they are **not** lying to you. Their brain **is** lying to them.
- Remember people with dementia are doing the best they can with the challenges they are facing in their brain!



[Click here to return to the table of contents.](#)

Chapter 6

6.3 Understanding Dementia: As the Brain Deteriorates What Stays and What Goes

Dementia Is BRAIN FAILURE--- MORE Than Just Memory Loss!

May involve changes in:

- **Short** Term Memory (Time Traveling and Getting Lost in Place)
- **Ability** to work with numbers/math/money
- **Body** Sensations
 - Can still have pain but cannot describe where it is located.
 - Hypersensitivity (higher sensitivity) in Mouth, Palms of the Hands, Bottom of the Feet and Genital Areas.
 - Still have the feelings of hunger, coldness, urination, constipation but not as easy to recognize or communicate so instead they get restless and irritable.
- **Vision**-People have Tunnel Vision so that they don't see on either side of themselves nor do they look up or down without prompting.
- **Taste Buds**—Sweet remains most intact (People like food sweet and cold)
- **Hallucinations** and Delusions-i.e. sensing and thinking incorrectly. The person can misinterpret what is happening in the environment. This is very real to the person and can be scary!
- **Emotions**---May More Easily Lose Control
- **Language**-Understanding & using words & concepts-People will talk around and use incorrect words to describe or name an object.
- **Decision** Making, Judgment, & Problem Solving (called Executive Skills)
- **Insight**—Awareness that there is a problem and what it is. People with dementia usually do NOT realize they are sick. It is best not to argue about this issue.



What Usually Remains INTACT?

- Automatic social responses (greetings, handshakes)
- Long term memories
- Skills that were learned early in life (age birth to 25ish)
- Desire to remain in control
- Music and rhythm



Six Suggestions that WORK

1. Get To Know People

- A person's history. The little things in the day count!!
- What are their patterns & familiar routines?
- What is their past?--likes, dislikes, fears—may show themselves in different ways now—but very important knowledge.
- People need to feel useful— that their presence matters—that they are helping somehow....about all the activities of the day.....in what manner do the tasks of the day get done?
- It can become very easy to pay more attention to the task itself than the person...this is a huge challenge.



2. Pay Attention to Visual Cues!!

- Your facial expressions.
- Your head motions.
- Your movements people will mimic (copy) your actions.
- Avoid an angry/confrontational stance & finger pointing.
- Match visual cues to vocal & touch cues--(ie. Take coats & suitcases out of sight, make beds, take away finished food. etc.)

3. Use Vocal Cues

- Avoid “parent voice.”
- Avoid high sing/song pitch.
- Avoid anything resembling the “royal we.”
- Avoid all correcting and arguing!!!!!!
- Use conversational mode but make requests short and sweet.
- Ask don’t tell. “Do me a favor”, “Would you mind,” “Tell you what, I need”
- Say I’m sorry frequently—“I’m sorry I made you angry,” “I’m sorry, this is hard,” “I’m sorry, I embarrassed you.”

4. Pay Attention to The ORDER of Tasks (called Sequencing)

- Go brush your teeth.....how many steps in this request?
- Think through tasks to the “hidden assumptions”—crucially important!!
- Identify what parts of sequence are still available to the person...usually those skills were established before age 25.
- Model behaviors you want—i.e. dry hands, scrape feet on carpet, hold on to rail.
- Use appropriate visual cues to match your voice—i.e. pretend to unbutton or use zipper, make washing motions with washcloth, pick up spoon to eat ice cream.



5. Always, Always, Always USE POSITIVE APPROACH™

- Approach From the FRONT-NOT From the Side or From Behind a Person!!
- Go SLOW.
- Get LOW-Match Person's Eye Level.
- Pause At the EDGE of Public Space (about 1 & ½ arms' length)
- Offer Your HAND With a Greeting and a Smile.
- Use The Person's NAME (Which Name?) and Introduce Yourself.
- Wait For a RESPONSE
- Wait For the PERSON To Allow You to Move In Closer.
- Get To the SIDE---The PERSON'S Dominant Side.
- Use HAND UNDER HAND Assistance.

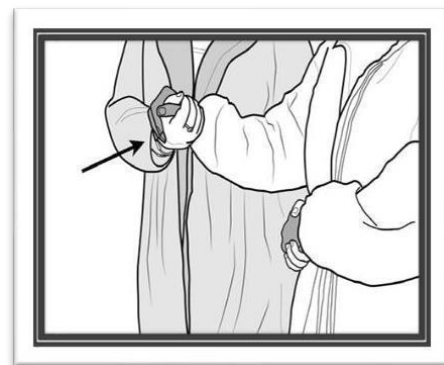

6. Use Hand UNDER Hand Assistance™

- Offer your hand to the person's dominant hand.
- Slide your hand around so that the thumbs are encircling and the person's hand is on TOP of your hand. Your hand is underneath theirs.
- Move to the person's side.

Uses of this Stance

- Use this stance to exert light palm pressure-which can be calming.
- Use this stance to gauge a person's response to touch.
- Use this stance to allow a person to have some privacy in personal care.
- Use this stance to establish safe physical boundaries.
- Use this stance to guide the person's hand and arm movement.

Your Other Hand

- Can place on the person's shoulder if they will tolerate a little light pressure.
- Can hold on to the person's opposite hand to steady while walking.
- Can use to assist in personal care.

**Used with permission by Positive Approach to Care (PAC) 2025. For more information and other training materials, go to www.teepasnow.com.*

Click here to return to the table of contents.

Chapter 6

6.4 Understanding Dementia: Managing Common Behaviors-- Wandering, Bathing, Toileting, Sleeping, Eating

“Behaviors Are NOT Problems, Behaviors ARE Messages.” (Rose Marie Fagan, Pioneer Network)

Hallucinations And Delusions

- Very, very common as the brain deteriorates.
- Completely REAL to the person. Can be scary or harmless. Can also be based in something real like shadows or noises that the person misnames.
- Hallucinations-seeing, hearing, smelling, tasting, feeling things that are not there.
- Delusions-Believing that things are happening that are not happening.

Suggestions

- Do NOT argue or try to reason with the person.
- In other words---“Go with the flow of conversation.” “Get on the bus and go where it’s going.”
- Ignore a hallucination that is not causing a problem.
- Offer reassurance if it is scary to them.
- Stay calm – do not show anger or frustration.
- Distract the person and refocus their attention.
- Remember that the person’s behavior is the result of physical changes beyond their control.
- Medications can be helpful in quieting the person’s anxiety—talk to your doctor.



Wandering-Ideas to Consider

- People with all forms of dementia can get lost in places that were previously well known to them.
- This can happen in driving early in the process so it can be important to not have them drive alone or stop driving all together with a dementia diagnosis.
- Later on, it is common for people to think they have something to do so they go outside and then can wander away without realizing where they are going.

Suggestions

- If a person has never gotten lost, it is STILL important to plan for a day when they might wander.
- Make sure the person has some form of ID on them in case they are found wandering.
- Consider enrolling in the Medic Alert/Safe Return program which gives a bracelet that is hard to remove with information on it. Get one for both you and the person.
www.alz.org
- Enroll in the State Next of Kin Registry program if they have a driver's license or state ID. www.bmv.ohio.gov
- If they will wear one, have an emergency response system necklace that they wear and notifies a central line if they fall or get lost.
- If people carry a phone, put a tracking app on their phone or even an air tag or trackable tile on their shoes or wallet. These items use GPS to monitor a person's movements.
- Put warning bells on doors, windows and other access points to the outside.
- Find ways to lock doors at night so that the person cannot leave without someone knowing.
- Hide keys, coats, suitcases and other visual cues that may cause someone to think they have to leave.
- Notify neighbors and others to your situation so they can be on watch in case they see someone starting to wander.
- Some communities have emergency responders who can be notified if a person is at risk of wandering.

Bathing/Showering/Cleanliness

Why Do These Activities Become Challenging?

- People think they have already bathed/showered that day.
- These are private activities and most people are not comfortable with others assisting or asking questions.
- People don't smell themselves or notice the soiled clothing they are wearing.
- People don't want to be cold and they are cold more and more often.
- People become afraid of water especially on their head and face region.
- Movement and mobility become challenging and bathrooms are places where many falls and accidents happen.



Suggestions

- Think about how often people really need to shower/bathe for realistic health and safety concerns—probably not every day.
- Prepare the space: add a shower chair and hand-held spray nozzle, warm the towels/washcloths first, have calm music playing.
- If people have a history of hair styling or grooming at a shop, make a weekly appointment at the salon/barber to get a wash, set and/or trim.
- Offer incentives like lunch with a grandchild or some other special treat for after the shower.
- In a pinch, purchase some cleaning products which are no rinse and allow people to get clean and get hair washed.
- Have several sets of similar clothing to exchange/substitute for when people do get undressed to shower or bathe.

Toileting Challenges

- People may also be on medications which can contribute to many types of incontinence and constipation challenges.
- With dementia, people struggle with language so they may not be able to tell you if they are uncomfortable.
- Urinary tract infections are common in dementia and they generally cause greater confusion in people.

Suggestions

- Make sure people are drinking enough fluids and eating fiber during the day. May have to add some products to people's diets as dementia progresses. Talk to your healthcare provider.
- Remind people about using the bathroom on a regular schedule as often they do not get the reminders any longer. Remember that people are not having accidents on purpose.
- There are many adult incontinence products to assist in keeping accidents from soiling clothing, bedding and furniture. Look for products that resemble regular underwear— resist the urge to call these products diapers...adults are not children and this language is demeaning to them.

The Sleep-Wake Cycle

- People with dementia often struggle with maintaining a healthy sleep/wake cycle.
- Either they sleep during the day and are up at night or they are up and down all night and wandering the house.
- People with dementia often struggle with evenings as well. They tend to be more confused later in the afternoon and evening and have more hallucinations and delusions then. We call this "Sundowners Syndrome."
- Care partners end up exhausted as they are often up at night with the person and still up during the day.

Suggestions

- Pay attention to the environment in the evenings: lots of shadows, outside stimulation and noise can be a problem. Calming, familiar music and old movies can be helpful. Generally modern TV is not helpful.
- Prioritize sleep as a care partner....pay attention to your own sleep so you are fresh to provide care.

Eating/Drinking: Common Challenges

- As people's brains deteriorate with dementia, getting enough food and drink into people can become challenging.
- People forget to eat and drink or think they already have; also they may eat over and over again if the food is a visual cue in front of them.
- People can dislike textures or flavors that are new or different and food often needs more seasoning to taste good to them.
- People can forget how to use silverware or need specially adapted silverware to eat. Eating with hands is common and finger foods can often be successfully offered.

Suggestions

- People crave SWEET AND COLD FOODS and may eat foods in odd combinations.
- People may need nutritional supplements as their diets become more limited in variety.
- As the brain deteriorates, chewing and swallowing can become challenging and people often need softer textured foods or thicker liquids as they run the risk of choking and aspirating.

IF SOMETHING IS NOT WORKING

- Slow down and back off! Try it another way.
- Make Sure – you are:
 - Limiting verbal information.
 - Sending POSITIVE and FRIENDLY non-verbal cues.
 - Taking your time to CONNECT.
 - Letting the person know what you want – THINK about ONE step at a time.
 - Show them what you want – model it, gesture through it, point to it.
 - Respecting the person's personal & intimate space.



OUR GOAL FOR YOU

- Understand of what's happening with the person with dementia.
- Get Support so you both can survive and thrive together.
- Develop insight so you can have moments of joy with the person.

[Click here to return to the table of contents.](#)

CHAPTER 7

Helpful Websites and Resources

CHAPTER 7



Chapter 7

Helpful Websites and Resources

Websites Of Interest

Federal Government

<https://www.hhs.gov/aging/index.html>

Allows you to access federal government websites that have to do with aging issues (Medicare, Social Security, Veterans Administration, etc.) Also links to aging services websites in each state.

State of Ohio

www.aging.ohio.gov

Ohio Department of Aging website. Includes the Nursing Home and Long Term Care Directory. www.ltc.ohio.gov also has links to Area Agencies on Aging in the State of Ohio for local services.

Caregiver Information

- www.caregiver.org – Family Caregiver Alliance website with fact sheets and online discussions.
- www.nextstepincare.org – Checklists and other materials to explain caregiving issues.
- www.youtube.com – large website which has many, many helpful videos. Groups that have good videos for family caregivers are Careblazers, UCLA, Mayo Clinic, Rural VA, Positive Approach to Care.

Health and Medication Information

www.medlineplus.gov. A comprehensive website of the US government which contains easy to read information on diseases, medications and treatments. Updated regularly.

Information for Adults with Disabilities –

www.disabilityrightsohio.org. Has many fact sheets on benefits, rights, and other important issues for those in Ohio with mental or physical disabilities.

Legal Issues in the State of Ohio –

www.proseniors.org. Includes easy to understand fact sheets on legal and benefit issues for residents of Ohio. It also offers limited legal advice through its phone number 800-488-6070. www.ohiolegalhelp.org. Includes basic legal information and forms as well as a referral services. Run by a non profit organization.

The Conversations Project –

<https://theconversationproject.org/>

Much information on how to have family conversations about future wishes and end-of-life care. Has checklists and booklets that give ideas and tools.

Dementia Resources--

- **Teepa Snow's Positive Approach to Care Website and Materials** (www.teepasnow.com) Book is ***Understanding the Changing Brain***, 2021.
- **Mayo Clinic on Alzheimer's Disease and other Dementias**, by Jonathan Graff-Radford and Angela Lunde, 2021.
- **Creating Moments of Joy**, by Jolene Brackey, 2017.
- **Website** of Dr. Natali Edmonds called www.careblazers.com which has many YouTube videos and other support for those with dementia and their families.
- **Zinnia TV** which is a subscription service which has many, many interesting videos and materials for those with dementia and their families. www.zinniatv.com
- **Website** of International Alzheimer's Assn. (www.alz.org)

National Family Caregiver Support Program

A nationally funded program operated in Central Ohio by the Central Ohio Area Agency on Aging (COAAA). It provides the caregiver workshops, and funds services designed to assist caregivers on a short-term basis. The services include: information and assistance, counseling, respite, and other supplemental services.

For more information, call 866-589-7277 or visit the COAAA website (www.coaaa.org). Or in your county, call one of these agencies:

SourcePoint (Delaware County)

740-363-6677

The Senior Hub of Fairfield County

740-681-5050

Community Action of Fayette County

740-335-7282

Franklin County Office on Aging

614-525-6200

Licking County Aging Partners

740-345-0821 or 800-452-0097

Madison County Senior Center

740-852-3001

Pickaway County Senior Center

740-474-8831

Union County Senior Services

800-248-2347 or 937-644-1010

Request a hard copy or download our other guides at www.coaaa.org or 614-645-7250

- Central Ohio Older Adults Resource Guide
- Central Ohio Older Adults Housing Guide
- Central Ohio Long Term Care & Hospice Guide
- Central Ohio Food & Utility Guide
- Central Ohio Support Group Guide
- Central Ohio Transportation Guide
- Central Ohio Moving & Transitions Guide
- Central Ohio Pet Care Guide
- Central Ohio Kinship Care Guide
- Central Ohio In Home & Hiring Guide

Click here to return to the table of contents.

MEDICARE

MEDICARE FOR BEGINNERS WORKSHOPS

ARE YOU NEW TO MEDICARE?

DO YOU NEED HELP UNDERSTANDING YOUR OPTIONS?

Central Ohio Area Agency on Aging's (COAAA) Medicare for Beginners workshops provide unbiased information to help you make informed decisions.

Visit www.coaaa.org/medicare to view the workshop schedule.

Registration is required. Email Andy Haggard, COAAA Medicare Outreach Specialist, at ahaggard@coaaa.org to register. Please note that workshops vary in start time and between virtual Zoom and in-person meetings. In-person meetings are located at **COAAA, 3776 S. High St., Columbus, OH 43207.**

You can always call COAAA for your Medicare questions.

Call **800-589-7277** or email medicare@coaaa.org.

COAAA does not represent or sell insurance products.

This advertisement was supported by the Administration for Community Living (ACL), U.S. Department of Health and Human Services (HHS) as part of a financial assistance award totaling \$145,000 with 100 percent funding by ACL/HHS. The contents are those of the author and do not necessarily represent the official views of, nor an endorsement, by ACL/HHS, or the U.S. Government.



Your
Connection
to Care

Funded in part by:





*Caring for a loved one, but don't know where to start?
Start with COAAA and Trualta! Access online caregiving
resources on your own time and at your own pace.*

Trualta is a FREE online learning platform designed to give caregivers the knowledge and skills needed to care for a loved one in the home.

With articles, videos, tip sheets, and professional-level training, there is something for everyone.

Trualta:

- Offers practical caregiving tips and techniques
- Covers caregiver topics, including personal care, brain health, safety, self-care, managing challenging behaviors, and more
- Connects caregivers to local resources
- Provides opportunities to connect with caregivers
- Can be accessed from any computer or mobile device connected to the internet



TRUALTA

coaaa.trualta.com

To learn more, call 800-589-7277
or visit coaaa.trualta.com



Your
Connection
to Care